

REVISION HISTORY					
REV	DESCRIPTION	DATE	REVISED	APPROVED	
A0	DRAWING RELEASED	2014-05-09	CARDINAL.Noel	XIAO.Shirley	
A1	REMOVED MESH GASKET FOAM AND 2 TAP SCREWS FIXING THE FRONT-REAR CABINET. REPLACED MESH BACKING FROM CLOTH TO FOAM.	2014-07-31	CARDINAL.Noel	XIAO.Shirley	
A2	CHANGED QTY OF ITEM 28 AND 29 TO MATCH BOM. MOVED ITEM 42 AND 43 TO CABINET ASSY.	2014-08-15	CARDINAL.Noel	XIAO.Shirley	

43	G58-00000-71671	4	PLA-POAPL/GROMMET B/BK	022-00000-71672
42	G58-00000-71669	3	PLA-POAPL/GROMMET A/BK	022-00000-71670
41	F92-00001-15394	1	MI-POAPLMESH SPONGE/BK	022-00001-15391
40	A65-00000-63224	1	MET-POAPLMESH/BKSR	022-00000-63223
39	A04-APL00-97000	1	SAM-POAPL/COM/AMP	
38	F88-50350-20217	13	SC-A05'35-02-B-ZP-BLK[R]	
37	F88-40180-20217	8	SC-A04'18-02-B-ZP-BLK[R]	
36	F88-60080-30297	3	SC-M06'08-03-B-ZP-BLK[R]	
35	F88-50150-30247	14	SC-A05'18-03-B-ZP-BLK[R]	
34	F88-40100-30247	12	SC-BT04'10-03-B-ZP-BLK[R]	
33	F88-00000-67369	1	SC-A3.5MM/18MM/PAN/BK	
32	F88-30080-30247	1	SC-BT03'08-03-B-ZP-BLK[R]	
31	F83-10044-05631	2	MI-COAT/CLIP4MM/4[R]	
30	F97-00000-66903	1	MI-POAPL/RUBBER GASKET/BK	022-00000-71648
29	F97-00000-82248	532.00 mm	MI-POAPL/HORN GASKET/BK	022-00000-82249
28	G58-00100-03180	1514.00 mm	LS-RGA15EVA1 SA	
27	G58-00000-73816	1	PLA-POAPL/GASKET/BK	022-00000-73822
26	A65-00001-05480	1	MET-POAPL/TWEETER BRACKET	
25	I68-00000-71037	1	PLA-P0000/DW	022-00000-70890
24	I68-00000-71047	1	PLA-P0000/BK	022-00000-70814
23	G58-00000-63146	1	PLA-POAPL/HORN/BK	022-00000-63144
22	G58-00000-63145	1	PLA-POAPL/HORN/BK	022-00000-63143
21	G58-00000-63138	1	PLA-POAPL/CABINET/BK	022-00000-63136
20	F97-00000-67306	2	MI-POAPL/ACOUSTIC FOAM	022-00000-71658
19	F88-50200-30297	8	SC-M05'20-03-B-ZP-BLK[R]	
18	F88-40250-20247	3	SC-BT04'25-02-B-ZP-BLK[R]	
17	F88-40200-20297	4	SC-M04'20-02-B-ZP-BLK[R]	
16	F88-40120-20217	2	SC-A04'12-02-B-ZP-BLK[R]	
15	F85-00000-67324	2	SC-NUHEXSC/TNUT/M16MM/12MM/SR	
14	F85-00000-67317	2	SC-NUHEXSC/TNUT/M10MM/31.6MM/BK	
13	F85-00000-67323	4	SC-NUHEXSC/TNUT/M10MM/8MM/SR	
12	F85-00000-67318	4	SC-NUHEXSC/TNUT/M5MM/25.3MM/BK	
11	F85-00000-67327	4	SC-NUHEXSC/TNUT/M4MM/4.5MM/SR	
10	F96-00000-67320	2	SC-WA/i 7MM/30MM/2MM/SR	
9	F96-00000-67322	2	SC-WA/i 6.2MM/25MM/4.2MM/SR	
8	F96-00000-67319	4	SC-WA/i 0.5MM/21MM/1.5MM/SR	
7	F96-00000-67321	4	SC-WA/i 0.5MM/16MM/2.5MM/SR	
6	G51-00000-66896	1	PLA-POAPL/RUBBER FEET C/BK	022-00000-71647
5	G51-00000-66895	2	PLA-POAPL/RUBBER FEET B/BK	022-00000-71646
4	G51-00000-66894	2	PLA-POAPL/RUBBER FEET A/BK	022-00000-71644
3	A65-00000-66925	4	MET-POAPL/NUT	022-00000-71616
2	A65-00000-97830	2	MET-POAPL/HANDLE/PANTONEBLACK	022-00000-63148
1	G58-00000-63139	1	PLA-POAPL/CABINET/BK	022-00000-63137

ITEM	ITEM NUMBER	QTY	ITEM CODE	CONSTRUCTION NO.																	
MECHANICAL PARTS LIST																					
<table border="0"> <tr> <td rowspan="4" style="text-align: center;"></td> <td>PROJECT:</td> <td>POAPL</td> <td>CREATED:</td> <td>CARDINAL.Noel</td> </tr> <tr> <td>CHECKED:</td> <td>CARDINAL.Noel</td> <td>DATE:</td> <td>2014-08-15</td> </tr> <tr> <td>APPROVED:</td> <td>XIAO.Shirley</td> <td>SCALE:</td> <td>1:5</td> </tr> <tr> <td>DRAWING NUMBER:</td> <td>A2</td> <td>014-00000-95145</td> <td>SHEET 1 OF 2</td> </tr> </table>						PROJECT:	POAPL	CREATED:	CARDINAL.Noel	CHECKED:	CARDINAL.Noel	DATE:	2014-08-15	APPROVED:	XIAO.Shirley	SCALE:	1:5	DRAWING NUMBER:	A2	014-00000-95145	SHEET 1 OF 2
	PROJECT:	POAPL	CREATED:	CARDINAL.Noel																	
	CHECKED:	CARDINAL.Noel	DATE:	2014-08-15																	
	APPROVED:	XIAO.Shirley	SCALE:	1:5																	
	DRAWING NUMBER:	A2	014-00000-95145	SHEET 1 OF 2																	

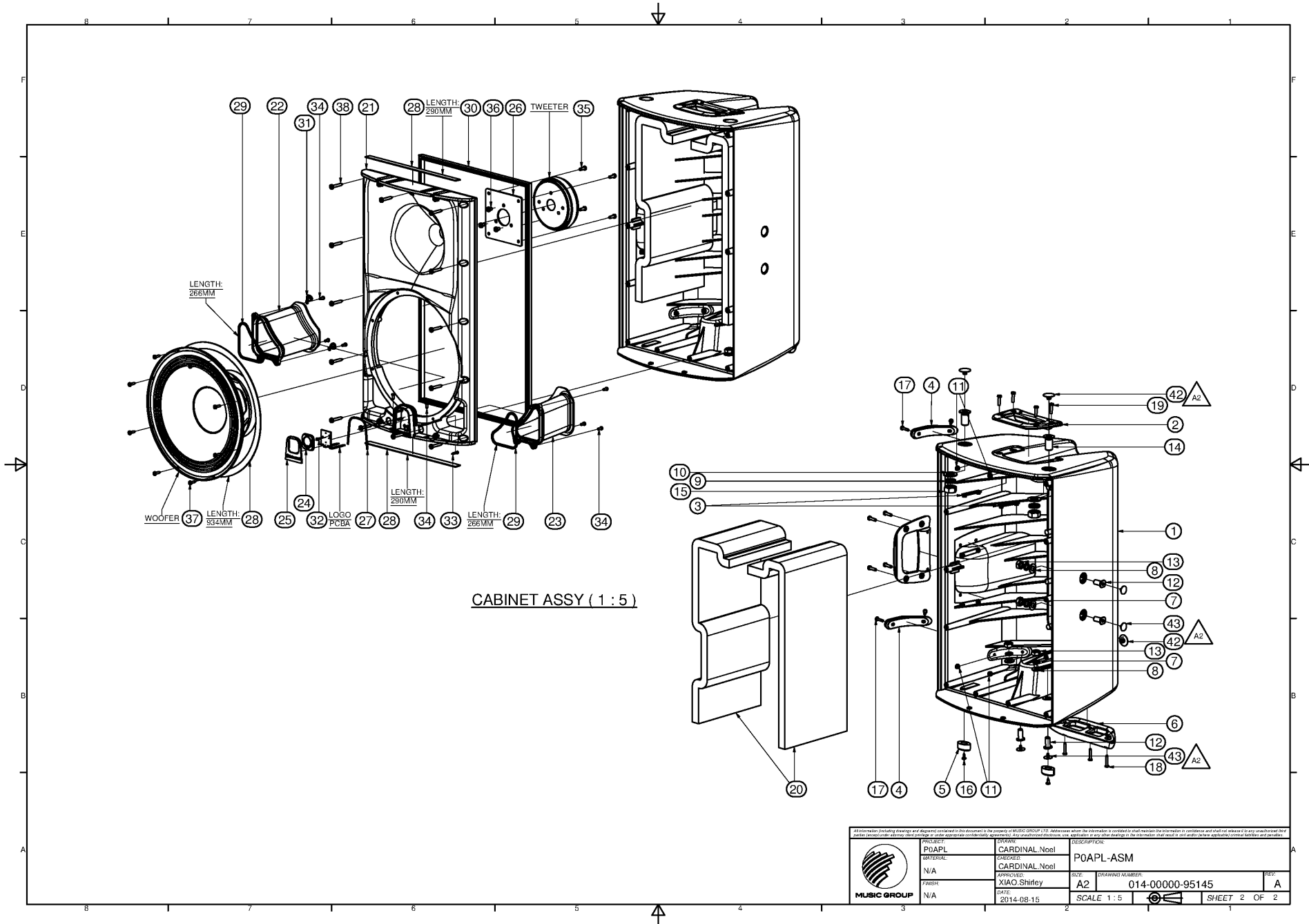

		<small>All information (including drawings) and diagrams contained in this document is the property of MUSIC GROUP LTD. Reproduction without the information is prohibited. All rights reserved. No part of this document may be reproduced, stored in a retrieval system, or transmitted in any form or by any means, electronic, mechanical, photocopying, recording, or by any information storage and retrieval system, without the prior written permission of MUSIC GROUP LTD.</small>	
PROJECT:	POAPL	DRAWN:	CARDINAL.Noel
DATE:	N/A	CHECKED:	CARDINAL.Noel
FINISH:	N/A	APPROVED:	XIAO.Shirley
		DATE:	2014-08-15
		SIZE:	A2
		DRAWING NUMBER:	014-00000-95145
		SCALE:	1 : 5
		SHEET:	2 OF 2