

AN78xxR/AN78MxxR Series

4-pin positive output voltage regulator with reset pin (1 A/500 mA type)

■ Overview

The AN78xxR series and the AN78MxxR series are the fixed positive output type monolithic voltage regulators with reset pin. Stabilized fixed output voltage is obtained from unstable DC input voltage without using any external components. Three types of output voltage, 5V, 9V and 12V, are available for the AN78xxR series, and four types, 5V, 8V, 9V and 12V, are available for the AN78MxxR series. They can be used in power circuits with current capacity of 1A/500mA. On/off of output voltage can be controlled by the reset pin.

■ Features

- No external components
- Maximum output current: 1A (AN78xxR)
500mA (AN78MxxR)
- Output voltage: 5V, 9V, 12V (AN78xxR)
5V, 8V, 9V, 12V (AN78MxxR)
- Built-in overcurrent limit circuit
- Built-in thermal overload protection circuit
- Built-in ASO (area of safe operation) protection circuit
- On/off of output voltage can be controlled by reset pin

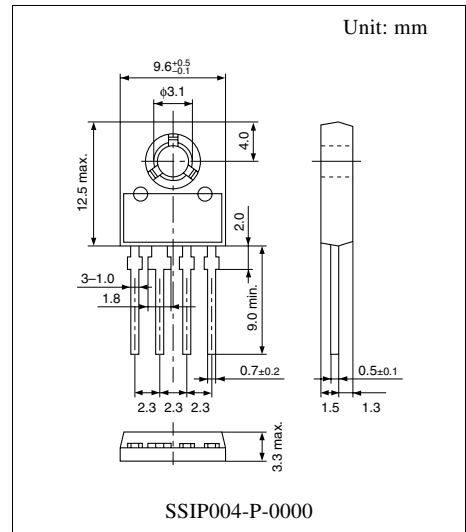

■ Block Diagram

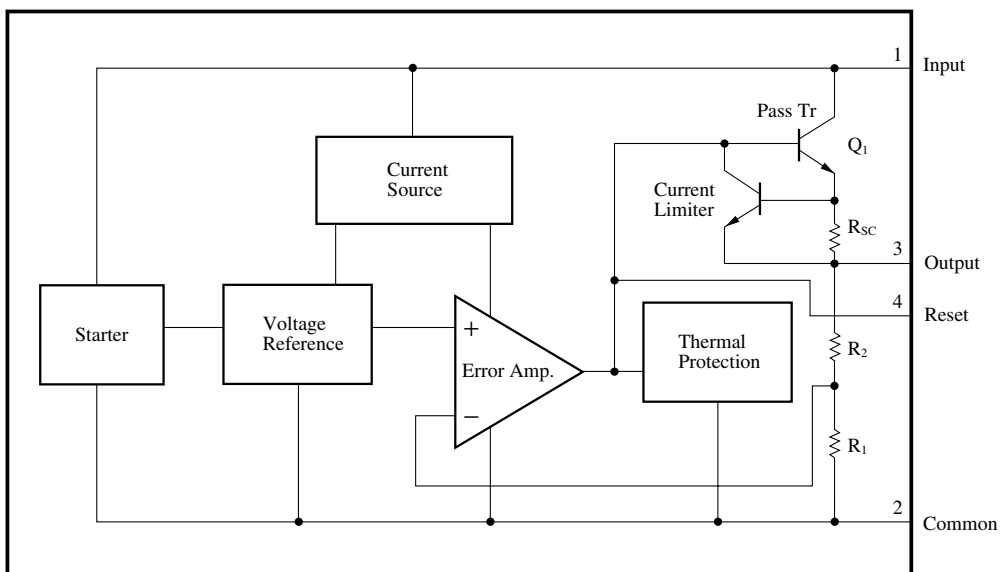

■ Absolute Maximum Ratings at $T_a = 25^\circ\text{C}$

Parameter	Symbol	Rating	Unit
Input voltage	V_I	35	V
Power dissipation	P_D	10 *	W
Operating ambient temperature	T_{opr}	-20 to +80	$^\circ\text{C}$
Storage temperature	T_{stg}	-55 to +150	$^\circ\text{C}$

* Follow the derating curve. When T_j exceeds 150°C , the internal circuit cuts off the output.

■ Electrical Characteristics at $T_a = 25^\circ\text{C}$

[1] AN78xxR series

• AN7805R (1A, 5V type)

Parameter	Symbol	Conditions	Min	Typ	Max	Unit
Output voltage	V_O	$T_j = 25^\circ\text{C}$	4.8	5	5.2	V
Output voltage tolerance	V_O	$V_I = 8$ to 20V , $I_O = 5\text{mA}$ to 1A , $T_j = 0$ to 125°C , $P_D \leq 15\text{W}$	4.75	—	5.25	V
Line regulation	REG_{IN}	$V_I = 7.5$ to 25V , $T_j = 25^\circ\text{C}$	—	3	100	mV
		$V_I = 8$ to 12V , $T_j = 25^\circ\text{C}$	—	1	50	mV
Load regulation	REG_L	$I_O = 5\text{mA}$ to 1.5A , $T_j = 25^\circ\text{C}$	—	15	100	mV
		$I_O = 250$ to 750mA , $T_j = 25^\circ\text{C}$	—	5	50	mV
Bias current	I_{Bias}	$T_j = 25^\circ\text{C}$	—	3.9	8	mA
Bias current fluctuation to input	$\Delta I_{Bias(IN)}$	$V_I = 7.5$ to 25V , $T_j = 25^\circ\text{C}$	—	—	1.3	mA
Bias current fluctuation to load	$\Delta I_{Bias(L)}$	$I_O = 5\text{mA}$ to 1A , $T_j = 25^\circ\text{C}$	—	—	0.5	mA
Output noise voltage	V_{no}	$f = 10\text{Hz}$ to 100kHz	—	40	—	μV
Ripple rejection ratio	RR	$V_I = 8$ to 18V , $I_O = 100\text{mA}$, $f = 120\text{Hz}$	62	—	—	dB
Minimum input/output voltage difference	$V_{DIF(min)}$	$I_O = 1\text{A}$, $T_j = 25^\circ\text{C}$	—	2	—	V
Output impedance	Z_O	$f = 1\text{kHz}$	—	17	—	$\text{m}\Omega$
Output short-circuit current	$I_{O(Short)}$	$V_I = 35\text{V}$, $T_j = 25^\circ\text{C}$	—	700	—	mA
Peak output current	$I_{O(Peak)}$	$T_j = 25^\circ\text{C}$	—	2	—	A
Output voltage temperature coefficient	$\Delta V_O/T_a$	$I_O = 5\text{mA}$, $T_j = 0$ to 125°C	—	-0.3	—	$\text{mV}/^\circ\text{C}$
Output voltage at reset	$V_{O(Reset)}$	$T_j = 25^\circ\text{C}$, $I_{I(Reset)} = 1\text{mA}$	—	—	1	V
Reset input current	$I_{I(Reset)}$	$T_j = 25^\circ\text{C}$	—	—	1	mA

Note 1) The specified condition $T_j = 25^\circ\text{C}$ means that the test should be carried out within so short a test time (within 10ms) that the characteristic value drift due to the chip junction temperature rise can be ignored.

Note 2) Unless otherwise specified, $V_I = 10\text{V}$, $I_O = 500\text{mA}$, $C_I = 0.33\mu\text{F}$, $C_O = 0.1\mu\text{F}$ and $T_j = 0$ to 125°C

■ Electrical Characteristics at $T_a = 25^\circ\text{C}$ (continued)

• AN7809R (1A, 9V type)

Parameter	Symbol	Conditions	Min	Typ	Max	Unit
Output voltage	V_O	$T_j = 25^\circ\text{C}$	8.65	9	9.35	V
Output voltage tolerance	V_O	$V_I = 12$ to 24V , $I_O = 5\text{mA}$ to 1A , $T_j = 0$ to 125°C , $P_D \leq 15\text{W}$	8.55	—	9.45	V
Line regulation	REG _{IN}	$V_I = 11.5$ to 26V , $T_j = 25^\circ\text{C}$	—	7	180	mV
		$V_I = 12$ to 18V , $T_j = 25^\circ\text{C}$	—	2	90	mV
Load regulation	REG _L	$I_O = 5\text{mA}$ to 1.5A , $T_j = 25^\circ\text{C}$	—	12	180	mV
		$I_O = 250$ to 750mA , $T_j = 25^\circ\text{C}$	—	4	90	mV
Bias current	I_{Bias}	$T_j = 25^\circ\text{C}$	—	3.9	8	mA
Bias current fluctuation to input	$\Delta I_{\text{Bias(IN)}}$	$V_I = 11.5$ to 26V , $T_j = 25^\circ\text{C}$	—	—	1	mA
Bias current fluctuation to load	$\Delta I_{\text{Bias(L)}}$	$I_O = 5\text{mA}$ to 1A , $T_j = 25^\circ\text{C}$	—	—	0.5	mA
Output noise voltage	V_{no}	$f = 10\text{Hz}$ to 100kHz	—	57	—	μV
Ripple rejection ratio	RR	$V_I = 12$ to 22V , $I_O = 100\text{mA}$, $f = 120\text{Hz}$	56	—	—	dB
Minimum input/output voltage difference	$V_{\text{DIF(min)}}$	$I_O = 1\text{A}$, $T_j = 25^\circ\text{C}$	—	2	—	V
Output impedance	Z_O	$f = 1\text{kHz}$	—	16	—	$\text{m}\Omega$
Output short-circuit current	$I_{\text{O(Short)}}$	$V_I = 26\text{V}$, $T_j = 25^\circ\text{C}$	—	700	—	mA
Peak output current	$I_{\text{O(Peak)}}$	$T_j = 25^\circ\text{C}$	—	2	—	A
Output voltage temperature coefficient	$\Delta V_O/T_a$	$I_O = 5\text{mA}$, $T_j = 0$ to 125°C	—	-0.5	—	$\text{mV}/^\circ\text{C}$
Output voltage at reset	$V_{\text{O(Reset)}}$	$T_j = 25^\circ\text{C}$, $I_{\text{I(Reset)}} = 1\text{mA}$	—	—	1	V
Reset input current	$I_{\text{I(Reset)}}$	$T_j = 25^\circ\text{C}$	—	—	1	mA

Note 1) The specified condition $T_j = 25^\circ\text{C}$ means that the test should be carried out within so short a test time (within 10ms) that the characteristic value drift due to the chip junction temperature rise can be ignored.

Note 2) Unless otherwise specified, $V_I = 15\text{V}$, $I_O = 500\text{mA}$, $C_I = 0.33\mu\text{F}$, $C_O = 0.1\mu\text{F}$ and $T_j = 0$ to 125°C

• AN7812R (1A, 12V type)

Parameter	Symbol	Conditions	Min	Typ	Max	Unit
Output voltage	V_O	$T_j = 25^\circ\text{C}$	11.5	12	12.5	V
Output voltage tolerance	V_O	$V_I = 15$ to 27V , $I_O = 5\text{mA}$ to 1A , $T_j = 0$ to 125°C , $P_D \leq 15\text{W}$	11.4	—	12.6	V
Line regulation	REG _{IN}	$V_I = 14.5$ to 30V , $T_j = 25^\circ\text{C}$	—	10	240	mV
		$V_I = 16$ to 22V , $T_j = 25^\circ\text{C}$	—	3	120	mV
Load regulation	REG _L	$I_O = 5\text{mA}$ to 1.5A , $T_j = 25^\circ\text{C}$	—	12	240	mV
		$I_O = 250$ to 750mA , $T_j = 25^\circ\text{C}$	—	4	120	mV
Bias current	I_{Bias}	$T_j = 25^\circ\text{C}$	—	4	8	mA
Bias current fluctuation to input	$\Delta I_{\text{Bias(IN)}}$	$V_I = 14.5$ to 30V , $T_j = 25^\circ\text{C}$	—	—	1	mA
Bias current fluctuation to load	$\Delta I_{\text{Bias(L)}}$	$I_O = 5\text{mA}$ to 1A , $T_j = 25^\circ\text{C}$	—	—	0.5	mA
Output noise voltage	V_{no}	$f = 10\text{Hz}$ to 100kHz	—	75	—	μV
Ripple rejection ratio	RR	$V_I = 15$ to 25V , $I_O = 100\text{mA}$, $f = 120\text{Hz}$	55	—	—	dB
Minimum input/output voltage difference	$V_{\text{DIF(min)}}$	$I_O = 1\text{A}$, $T_j = 25^\circ\text{C}$	—	2	—	V
Output impedance	Z_O	$f = 1\text{kHz}$	—	18	—	$\text{m}\Omega$
Output short-circuit current	$I_{\text{O(Short)}}$	$V_I = 35\text{V}$, $T_j = 25^\circ\text{C}$	—	700	—	mA
Peak output current	$I_{\text{O(Peak)}}$	$T_j = 25^\circ\text{C}$	—	2	—	A
Output voltage temperature coefficient	$\Delta V_O/T_a$	$I_O = 5\text{mA}$, $T_j = 0$ to 125°C	—	-0.8	—	$\text{mV}/^\circ\text{C}$
Output voltage at reset	$V_{\text{O(Reset)}}$	$T_j = 25^\circ\text{C}$, $I_{\text{I(Reset)}} = 1\text{mA}$	—	—	1	V
Reset input current	$I_{\text{I(Reset)}}$	$T_j = 25^\circ\text{C}$	—	—	1	mA

Note 1) The specified condition $T_j = 25^\circ\text{C}$ means that the test should be carried out within so short a test time (within 10ms) that the characteristic value drift due to the chip junction temperature rise can be ignored.

Note 2) Unless otherwise specified, $V_I = 19\text{V}$, $I_O = 500\text{mA}$, $C_I = 0.33\mu\text{F}$, $C_O = 0.1\mu\text{F}$ and $T_j = 0$ to 125°C

■ Electrical Characteristics at $T_a = 25^\circ\text{C}$ (continued)

[2] AN78MxxR series

• AN78M05R (500mA, 5V type)

Parameter	Symbol	Conditions	Min	Typ	Max	Unit
Output voltage	V_O	$T_j = 25^\circ\text{C}$	4.8	5	5.2	V
Output voltage tolerance	V_O	$V_I = 7.5$ to 20V , $I_O = 5$ to 350mA , $T_j = 0$ to 125°C , $P_D \leq 15\text{W}$	4.75	—	5.25	V
Line regulation	REG _{IN}	$V_I = 7.5$ to 25V , $T_j = 25^\circ\text{C}$	—	3	100	mV
		$V_I = 8$ to 25V , $T_j = 25^\circ\text{C}$	—	1	50	mV
Load regulation	REG _L	$I_O = 5$ to 500mA , $T_j = 25^\circ\text{C}$	—	20	100	mV
		$I_O = 5$ to 200mA , $T_j = 25^\circ\text{C}$	—	10	50	mV
Bias current	I_{Bias}	$T_j = 25^\circ\text{C}$	—	4.6	6	mA
Bias current fluctuation to input	$\Delta I_{\text{Bias(IN)}}$	$V_I = 8$ to 25V , $T_j = 25^\circ\text{C}$	—	—	0.8	mA
Bias current fluctuation to load	$\Delta I_{\text{Bias(L)}}$	$I_O = 5$ to 350mA , $T_j = 25^\circ\text{C}$	—	—	0.5	mA
Output noise voltage	V_{no}	$f = 10\text{Hz}$ to 100kHz	—	40	—	μV
Ripple rejection ratio	RR	$V_I = 8$ to 18V , $I_O = 100\text{mA}$, $f = 120\text{Hz}$	62	—	—	dB
Minimum input/output voltage difference	$V_{\text{DIF(min)}}$	$I_O = 500\text{mA}$, $T_j = 25^\circ\text{C}$	—	2	—	V
Output short-circuit current	$I_{\text{O(Short)}}$	$V_I = 35\text{V}$, $T_j = 25^\circ\text{C}$	—	300	—	mA
Peak output current	$I_{\text{O(Peak)}}$	$T_j = 25^\circ\text{C}$	—	700	—	mA
Output voltage temperature coefficient	$\Delta V_O/T_a$	$I_O = 5\text{mA}$, $T_j = 0$ to 125°C	—	-0.5	—	$\text{mV}/^\circ\text{C}$
Output voltage at reset	$V_{\text{O(Reset)}}$	$T_j = 25^\circ\text{C}$, $I_{\text{I(Reset)}} = 1\text{mA}$	—	—	1	V
Reset input current	$I_{\text{I(Reset)}}$	$T_j = 25^\circ\text{C}$	—	—	1	mA

Note 1) The specified condition $T_j = 25^\circ\text{C}$ means that the test should be carried out within so short a test time (within 10ms) that the characteristic value drift due to the chip junction temperature rise can be ignored.

Note 2) Unless otherwise specified, $V_I = 10\text{V}$, $I_O = 350\text{mA}$, $C_I = 0.33\mu\text{F}$, $C_O = 0.1\mu\text{F}$ and $T_j = 0$ to 125°C

• AN78M08R (500mA, 8V type)

Parameter	Symbol	Conditions	Min	Typ	Max	Unit
Output voltage	V_O	$T_j = 25^\circ\text{C}$	7.7	8	8.3	V
Output voltage tolerance	V_O	$V_I = 10.5$ to 23V , $I_O = 5$ to 350mA , $T_j = 0$ to 125°C , $P_D \leq 15\text{W}$	7.6	—	8.4	V
Line regulation	REG _{IN}	$V_I = 10.5$ to 25V , $T_j = 25^\circ\text{C}$	—	6	100	mV
		$V_I = 11$ to 25V , $T_j = 25^\circ\text{C}$	—	2	50	mV
Load regulation	REG _L	$I_O = 5$ to 500mA , $T_j = 25^\circ\text{C}$	—	25	160	mV
		$I_O = 5$ to 200mA , $T_j = 25^\circ\text{C}$	—	10	80	mV
Bias current	I_{Bias}	$T_j = 25^\circ\text{C}$	—	4.1	6	mA
Bias current fluctuation to input	$\Delta I_{\text{Bias(IN)}}$	$V_I = 10.5$ to 25V , $T_j = 25^\circ\text{C}$	—	—	0.8	mA
Bias current fluctuation to load	$\Delta I_{\text{Bias(L)}}$	$I_O = 5$ to 350mA , $T_j = 25^\circ\text{C}$	—	—	0.5	mA
Output noise voltage	V_{no}	$f = 10\text{Hz}$ to 100kHz	—	52	—	μV
Ripple rejection ratio	RR	$V_I = 11.5$ to 21.5V , $I_O = 100\text{mA}$, $f = 120\text{Hz}$	56	—	—	dB
Minimum input/output voltage difference	$V_{\text{DIF(min)}}$	$I_O = 500\text{mA}$, $T_j = 25^\circ\text{C}$	—	2	—	V
Output short-circuit current	$I_{\text{O(Short)}}$	$V_I = 35\text{V}$, $T_j = 25^\circ\text{C}$	—	300	—	mA
Peak output current	$I_{\text{O(Peak)}}$	$T_j = 25^\circ\text{C}$	—	0.7	—	A
Output voltage temperature coefficient	$\Delta V_O/T_a$	$I_O = 5\text{mA}$, $T_j = 0$ to 125°C	—	-0.5	—	$\text{mV}/^\circ\text{C}$
Output voltage at reset	$V_{\text{O(Reset)}}$	$T_j = 25^\circ\text{C}$, $I_{\text{I(Reset)}} = 1\text{mA}$	—	—	1	V
Reset input current	$I_{\text{I(Reset)}}$	$T_j = 25^\circ\text{C}$	—	—	1	mA

Note 1) The specified condition $T_j = 25^\circ\text{C}$ means that the test should be carried out within so short a test time (within 10ms) that the characteristic value drift due to the chip junction temperature rise can be ignored.

Note 2) Unless otherwise specified, $V_I = 14\text{V}$, $I_O = 350\text{mA}$, $C_I = 0.33\mu\text{F}$, $C_O = 0.1\mu\text{F}$ and $T_j = 0$ to 125°C

■ Electrical Characteristics at $T_a = 25^\circ\text{C}$ (continued)

• AN78M09R (500mA, 9V type)

Parameter	Symbol	Conditions	Min	Typ	Max	Unit
Output voltage	V_O	$T_j = 25^\circ\text{C}$	8.65	9	9.35	V
Output voltage tolerance	V_O	$V_I = 11.5$ to 24V , $I_O = 5$ to 350mA , $T_j = 0$ to 125°C , $P_D \leq 15\text{W}$	8.55	—	9.45	V
Line regulation	REG _{IN}	$V_I = 11.5$ to 25V , $T_j = 25^\circ\text{C}$	—	7	100	mV
		$V_I = 12$ to 25V , $T_j = 25^\circ\text{C}$	—	2	50	mV
Load regulation	REG _L	$I_O = 5$ to 500mA , $T_j = 25^\circ\text{C}$	—	25	180	mV
		$I_O = 5$ to 200mA , $T_j = 25^\circ\text{C}$	—	10	90	mV
Bias current	I_{Bias}	$T_j = 25^\circ\text{C}$	—	4.1	6.0	mA
Bias current fluctuation to input	$\Delta I_{\text{Bias(IN)}}$	$V_I = 12$ to 25V , $T_j = 25^\circ\text{C}$	—	—	0.8	mA
Bias current fluctuation to load	$\Delta I_{\text{Bias(L)}}$	$I_O = 5$ to 350mA , $T_j = 25^\circ\text{C}$	—	—	0.5	mA
Output noise voltage	V_{no}	$f = 10\text{Hz}$ to 100kHz	—	60	—	μV
Ripple rejection ratio	RR	$V_I = 12$ to 22V , $I_O = 100\text{mA}$, $f = 120\text{Hz}$	56	—	—	dB
Minimum input/output voltage difference	$V_{\text{DIF(min)}}$	$I_O = 500\text{mA}$, $T_j = 25^\circ\text{C}$	—	2	—	V
Output short-circuit current	$I_{\text{O(Short)}}$	$V_I = 35\text{V}$, $T_j = 25^\circ\text{C}$	—	300	—	mA
Peak output current	$I_{\text{O(Peak)}}$	$T_j = 25^\circ\text{C}$	—	0.7	—	A
Output voltage temperature coefficient	$\Delta V_O/T_a$	$I_O = 5\text{mA}$, $T_j = 0$ to 125°C	—	-0.5	—	$\text{mV}/^\circ\text{C}$
Output voltage at reset	$V_{\text{O(Reset)}}$	$T_j = 25^\circ\text{C}$, $I_{\text{I(Reset)}} = 1\text{mA}$	—	—	1	V
Reset input current	$I_{\text{I(Reset)}}$	$T_j = 25^\circ\text{C}$	—	—	1	mA

Note 1) The specified condition $T_j = 25^\circ\text{C}$ means that the test should be carried out within so short a test time (within 10ms) that the characteristic value drift due to the chip junction temperature rise can be ignored.

Note 2) Unless otherwise specified, $V_I = 15\text{V}$, $I_O = 350\text{mA}$, $C_I = 0.33\mu\text{F}$, $C_O = 0.1\mu\text{F}$ and $T_j = 0$ to 125°C

• AN78M12R (500mA, 12V type)

Parameter	Symbol	Conditions	Min	Typ	Max	Unit
Output voltage	V_O	$T_j = 25^\circ\text{C}$	11.5	12	12.5	V
Output voltage tolerance	V_O	$V_I = 14.5$ to 27V , $I_O = 5$ to 350mA , $T_j = 0$ to 125°C , $P_D \leq 15\text{W}$	11.4	—	12.6	V
Line regulation	REG _{IN}	$V_I = 14.5$ to 30V , $T_j = 25^\circ\text{C}$	—	8	100	mV
		$V_I = 16$ to 30V , $T_j = 25^\circ\text{C}$	—	2	50	mV
Load regulation	REG _L	$I_O = 5$ to 500mA , $T_j = 25^\circ\text{C}$	—	25	240	mV
		$I_O = 5$ to 200mA , $T_j = 25^\circ\text{C}$	—	10	120	mV
Bias current	I_{Bias}	$T_j = 25^\circ\text{C}$	—	4.3	6	mA
Bias current fluctuation to input	$\Delta I_{\text{Bias(IN)}}$	$V_I = 14.5$ to 30V , $T_j = 25^\circ\text{C}$	—	—	0.8	mA
Bias current fluctuation to load	$\Delta I_{\text{Bias(L)}}$	$I_O = 5$ to 350mA , $T_j = 25^\circ\text{C}$	—	—	0.5	mA
Output noise voltage	V_{no}	$f = 10\text{Hz}$ to 100kHz	—	75	—	μV
Ripple rejection ratio	RR	$V_I = 15$ to 25V , $I_O = 100\text{mA}$, $f = 120\text{Hz}$	55	—	—	dB
Minimum input/output voltage difference	$V_{\text{DIF(min)}}$	$I_O = 500\text{mA}$, $T_j = 25^\circ\text{C}$	—	2	—	V
Output short-circuit current	$I_{\text{O(Short)}}$	$V_I = 35\text{V}$, $T_j = 25^\circ\text{C}$	—	300	—	mA
Peak output current	$I_{\text{O(Peak)}}$	$T_j = 25^\circ\text{C}$, $V_I = 35\text{V}$	—	700	—	mA
Output voltage temperature coefficient	$\Delta V_O/T_a$	$I_O = 5\text{mA}$, $T_j = 0$ to 125°C	—	-0.5	—	$\text{mV}/^\circ\text{C}$
Output voltage at reset	$V_{\text{O(Reset)}}$	$T_j = 25^\circ\text{C}$, $I_{\text{I(Reset)}} = 1\text{mA}$	—	—	1	V
Reset input current	$I_{\text{I(Reset)}}$	$T_j = 25^\circ\text{C}$	—	—	1	mA

Note 1) The specified condition $T_j = 25^\circ\text{C}$ means that the test should be carried out within so short a test time (within 10ms) that the characteristic value drift due to the chip junction temperature rise can be ignored.

Note 2) Unless otherwise specified, $V_I = 19\text{V}$, $I_O = 350\text{mA}$, $C_I = 0.33\mu\text{F}$, $C_O = 0.1\mu\text{F}$ and $T_j = 0$ to 125°C

■ Main Characteristics

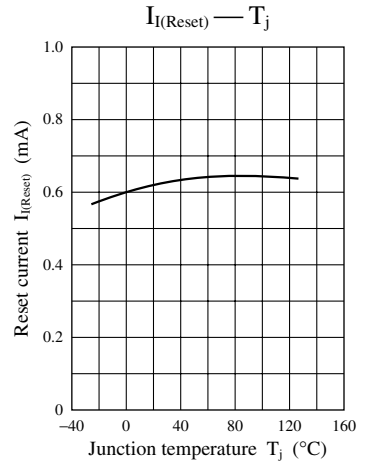
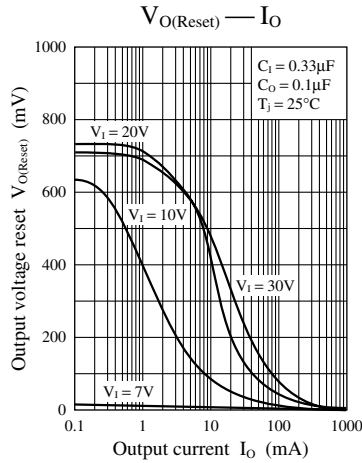
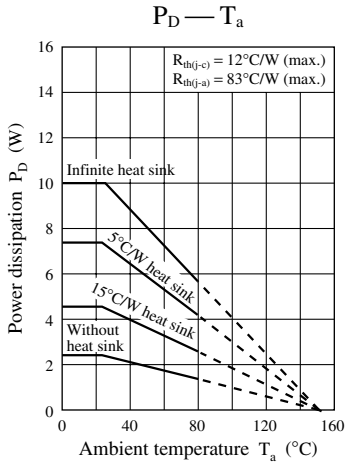

■ Basic Regulator Circuit

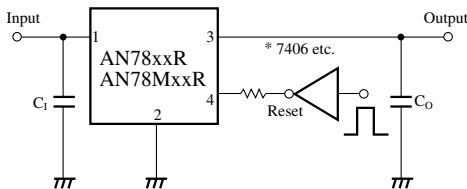

* For TTL, an open collector type inverter, buffer, gate etc. can be used.

Beware of the breakdown of TTL, as the reset pin bears voltage higher than the output voltage V_O by 1 to 2V.

C_1 is necessary when the input line is long.
 C_0 improves the transient response.

■ Application Circuit Example

1. Soft start circuit

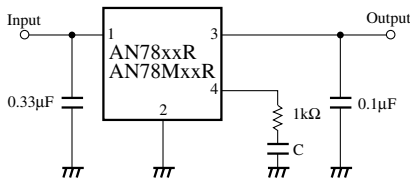

* Control of output voltage rise time

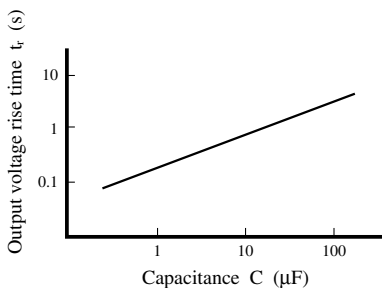

2. Several output reset circuits

