

# AN5285K

## Sound level automatic gain control IC

### ■ Overview

The AN5285K is a stereo automatic volume control IC for reducing a difference in volume between broadcasting stations and between programs. It is a kind of AGC circuit and reduces a sudden change in sound signal amplitude by using a proper time constant.

### ■ Features

- Sound level AGC function by VCA gain control
- Prevention of S/N ratio degradation by reducing VCA gain at no signal (typ. 20 mV[rms] or less)
- AGC function can be switched on and off externally.
- Operating point of VCA gain lowering is adjustable by means of external resistor.
- Usable for stereo sound system (also usable for monaural sound system) by two VCAs

### ■ Applications

- Televisions and video sets

### ■ Block Diagram

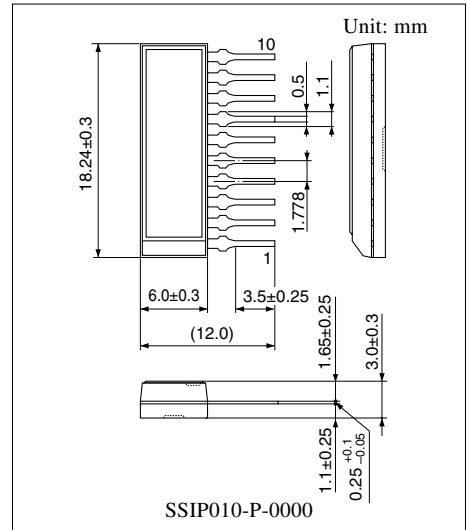
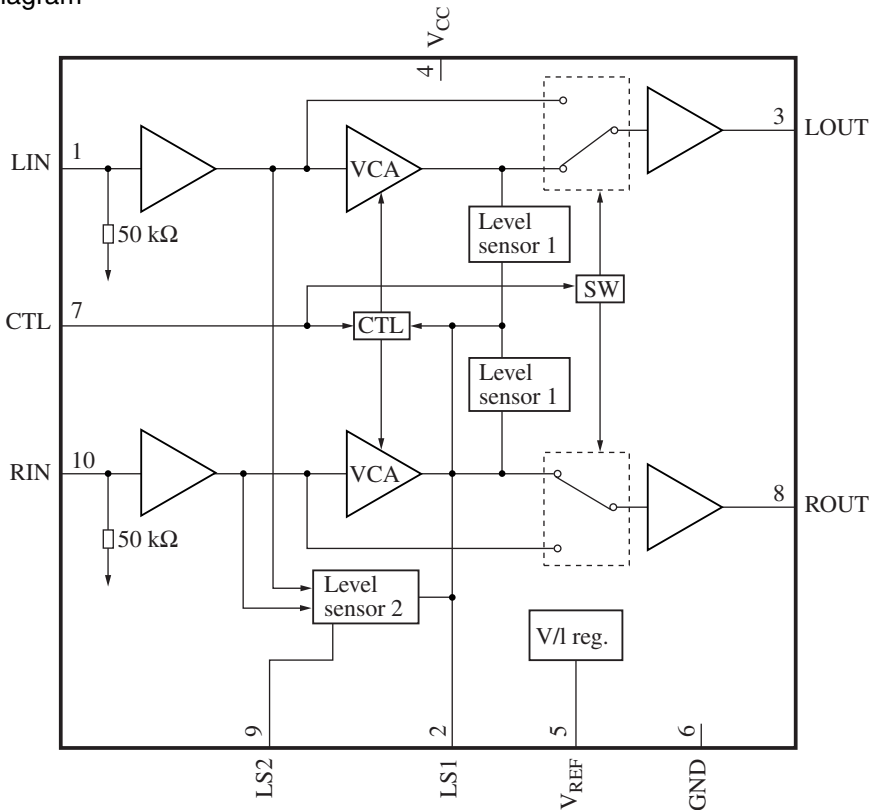

Note) The package of this product will be changed to lead-free type (SSIP010-P-0000A). See the new package dimensions section later of this datasheet.

### ■ Absolute Maximum Ratings

Parameter	Symbol	Rating	Unit
Supply voltage	$V_{CC}$	13.0	V
Supply current	$I_{CC}$	30	mA
Power dissipation	$P_D$	390	mW
Operating ambient temperature *	$T_{opr}$	-20 to +75	°C
Storage temperature *	$T_{stg}$	-55 to +150	°C

Note) \* : Except for the operating ambient temperature, and storage temperature, all ratings are for  $T_a = 25^\circ\text{C}$ .

### ■ Recommended Operating Range

Parameter	Symbol	Range	Unit
Supply voltage	$V_{CC}$	8.5 to 12.5	V

### ■ Electrical Characteristics at $V_{CC} = 12\text{ V}$ , $f_{IN} = 1\text{ kHz}$ , $T_a = 25^\circ\text{C}$

Parameter	Symbol	Conditions	Min	Typ	Max	Unit
Supply current *	$I_{CC}$	Without input signal	5	10	15	mA
Input and output level 1 *	V1	$V_{IN} = 1\text{ mV[rms]}$	0.7	1.0	1.4	mV[rms]
Input and output level 2 *	V2	$V_{IN} = 50\text{ mV[rms]}$	80	110	140	mV[rms]
Input and output level 3 *	V3	$V_{IN} = 200\text{ mV[rms]}$	150	200	250	mV[rms]
Input and output level 4 *	V4	$V_{IN} = 1\text{ V[rms]}$	200	280	360	mV[rms]
Input and output level 5	V5	$V_{IN} = 100\text{ mV[rms]}$ , $V_{ctl} = 2.5\text{ V}$	50	100	150	mV[rms]
Input and output level 6	V6	$V_{IN} = 300\text{ mV[rms]}$ , $V_{ctl} = 4.5\text{ V}$	230	300	370	mV[rms]
Total harmonic distortion *	THD	$V_{IN} = 200\text{ mV[rms]}$	—	0.1	0.5	%
Noise level *	$V_n$	No input signal (with IHF-A)	—	—	100	$\mu\text{V[rms]}$
Maximum input level *	$V_{max}$	Input level at THD = 1%	2.8	—	—	V[rms]
Crosstalk between channels	GT	$V_{IN} = 2\text{ V[rms]}$ , AGC off	60	—	—	dB
AGC OFF voltage	$V_{SW}$	$V_{IN} = 1\text{ V[rms]}$ , $V_{ctl} = 1.2\text{ V}$	890	1 000	1 130	mV[rms]
Channel balance *	CB	$V_{IN} = 200\text{ mV[rms]}$	-1.0	0	1.0	dB
Frequency characteristics *	FC	$V_{IN} = 200\text{ mV[rms]}$ Level difference of $f_{IN} = 1\text{ kHz}/20\text{ kHz}$	-1.0	0	1.0	dB
Input and output level 7	V7	$V_{IN} = 200\text{ mV[rms]}$ , AGC off	175	200	225	mV[rms]

Note) \* :  $V_{ctl} = 3.5\text{ V}$ .

■ Terminal Equivalent Circuits

Pin No.	Equivalent circuit	Description	Voltage
1		LIN: Left side input pin	6 V
2		LSI: AGC level sensor 1 and 2	0.5 V to 1.5 V
3		LOUT: Left side output pin	6 V
4	—	V <sub>CC</sub> : V <sub>CC</sub> pin	—
5		V <sub>REF</sub> : Reference voltage stability	6 V
6	—	GND: GND pin	—

### Terminal Equivalent Circuits (continued)

Pin No.	Equivalent circuit	Description	Voltage
7		CTL: AGC on/off changeover AGC off at 1.2 V or lower	—
8		ROUT: Right side output pin	6 V
9		LS2: AGC level sensor 2	6 V
10		RIN: Right side input pin	6 V

