

TOSHIBA

FILE NO. 020-200303

SERVICE MANUAL

COLOR TELEVISION

N3ES Chassis

36A43

(TAC0302)



TABLE OF CONTENTS

CHAPTER 1 GENERAL ADJUSTMENTS

SAFETY INSTRUCTIONS	3
SET-UP ADJUSTMENT	4
SERVICE MODE	6
DESIGN MODE	9
ELECTRICAL ADJUSTMENT	10
CIRCUIT CHECKS	12

CHAPTER 2 SPECIFIC INFORMATIONS

SETTING & ADJUSTING DATA	13
LOCATION OF CONTROLS	14
PROGRAMMING CHANNELS INTO THE TV'S MEMORY	15
CHASSIS AND CABINET REPLACEMENT PARTS LIST	16
PC BOARDS BOTTOM VIEW.....	25
TERMINAL VIEW OF TRANSISTORS	28
CIRCUIT BLOCK DIAGRAM	30
SPECIFICATIONS	END

APPENDIX:

CIRCUIT DIAGRAM

CHAPTER 1 GENERAL ADJUSTMENTS

SAFETY INSTRUCTIONS

WARNING: BEFORE SERVICING THIS CHASSIS, READ THE “X-RAY RADIATION PRECAUTION”, “SAFETY PRECAUTION” AND “PRODUCT SAFETY NOTICE” INSTRUCTIONS BELOW.

X-RAY RADIATION PRECAUTION

1. Excessive high voltage can produce potentially hazardous X-RAY RADIATION. To avoid such hazards, the high voltage must not be above the specified limit. The nominal value of the high voltage of this receiver is (A) kV at zero beam current (minimum brightness) under a 120V AC power source. The high voltage must not, under any circumstances, exceed (B) kV.

Refer to table-1 for high voltage (A), (B).
(See SETTING & ADJUSTING DATA on page 13)

Each time a receiver requires servicing, the high voltage should be checked following the HIGH VOLTAGE CHECK procedure in this manual. It is recommended that the reading of the high voltage be recorded as a part of the service record. It is important to use an accurate and reliable high voltage meter.
2. This receiver is equipped with a Fail Safe (FS) circuit which prevents the receiver from producing an excessively high voltage even if the B+ voltage increases abnormally. Each time the receiver is serviced, the FS circuit must be checked to determine that the circuit is properly functioning, following the FS CIRCUIT CHECK procedure in this manual.
3. The only source of X-RAY RADIATION in this TV receiver is the picture tube. For continued X-RAY RADIATION protection, the replacement tube must be exactly the same type tube as specified in the parts list.
4. Some part in this receiver have special safety-related characteristics for X-RAY RADIATION protection. For continued safety, parts replacement should be undertaken only after referring to the PRODUCT SAFETY NOTICE below.

SAFETY PRECAUTION

WARNING : Service should not be attempted by anyone unfamiliar with the necessary precautions on this receiver. The following are the necessary precautions to be observed before servicing this chassis.

1. An isolation Transformer should be connected in the power line between the receiver and the AC line before any service is performed on the receiver.
2. Always discharge the picture tube anode to the CRT conductive coating before handling the picture tube. The picture tube is highly evacuated and if broken, glass fragments will be violently expelled. Use shatter proof goggles and keep picture tube away from the unprotected body while handling.
3. When replacing a chassis in the cabinet, always be certain that all the protective devices are put back in place, such as; non-metallic control knobs, insulating covers, shields, isolation resistor-capacitor network etc.
4. Before returning the set to the customer, always perform an AC leakage current check on the exposed metallic parts of the cabinet, such as antennas, terminals, screwheads, metal overlays, control shafts etc. to be sure the set is safe to operate without danger of electrical shock. Plug the AC line cord directly into a 120V AC outlet (do not use a line isolation transformer during this check). Use an AC voltmeter having 5000 ohms per volt or more sensitivity in the following manner:

Connect a 1500 ohm 10 watt resistor, paralleled by a 0.15 μ F, AC type capacitor, between a known good earth ground (water pipe, conduit, etc.) and the exposed metallic parts, one at a time. Measure the AC voltage across the combination of 1500 ohm resistor and 0.15 μ F capacitor. Reverse the AC plug at the AC outlet and repeat AC voltage measurements for each exposed metallic part. Voltage measured must not exceed 0.3 volts rms. This corresponds to 0.2 milliamp. AC. Any value exceeding this limit constitutes a potential shock hazard and must be corrected immediately.

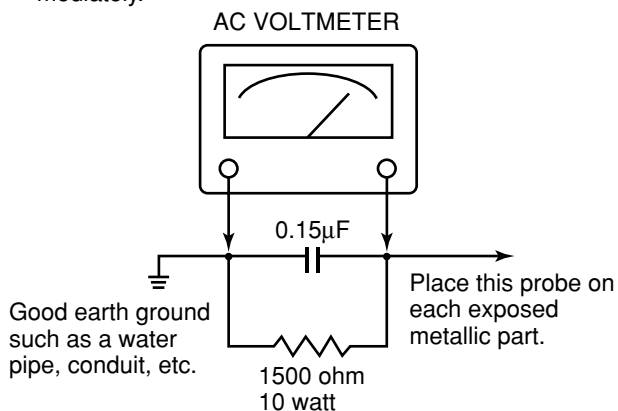

PRODUCT SAFETY NOTICE

Many electrical and mechanical parts in this chassis have special safety-related characteristics. These characteristics are often passed unnoticed by a visual inspection and the protection afforded by them cannot necessarily be obtained by using replacement components rated for higher voltage, wattage, etc. Replacement parts which have these special safety characteristics are identified in this manual and its supplements; electrical components having such features are identified by the international hazard symbols on the schematic diagram and the parts list.

Before replacing any of these components, read the parts list in this manual carefully. The use of substitute replacement parts which do not have the same safety characteristics as specified in the parts list may create shock, fire, X-ray radiation or other hazards.

WARNING: BEFORE SERVICING THIS CHASSIS, READ THE "X-RAY RADIATION PRECAUTION", "SAFETY PRECAUTION" AND "PRODUCT SAFETY NOTICE" ON PAGE 3 OF SERVICE MANUAL.

SET-UP ADJUSTMENT

■ The following adjustments should be made when a complete realignment is required or a new picture tube is installed. Perform the adjustments in order as follows :

1. Color Purity
2. Convergence
3. White Balance

Note: The PURITY/CONVERGENCE MAGNET assembly and rubber wedges need mechanical positioning. Refer to figure 1.

COLOR PURITY ADJUSTMENT

- (1) Let the screen face in the installing direction or toward the east (when it is to be moved), bring up the service mode screen after demagnetizing (front, left, right, and top) with the degaussing coil, receive white signals by pressing the [TV/VIDEO] button, and then the receiver should be operated for more than 40 minutes.
- (2) Perform rough adjustment of the central convergence with the P/C magnet according to the adjustment item.
- (3) Receive built-in green signals, loosen set screws on the deflection yoke, remove rubber wedges, and shift the deflection yoke toward front.
- (4) Move alternately the two 2-pole magnets of the P/C magnets so that the green raster can come to the center of the screen.

Figure 1.

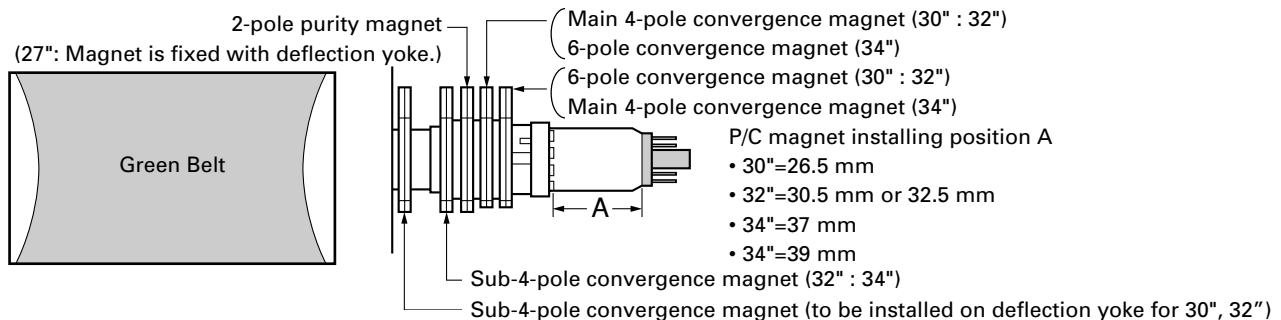

- (5) Receive built-in red and blue signals, check that there is no inclination of the single color raster toward one side, and if each color tilts to a great extent, make adjustment with the 2-pole magnet so that the 3 colors will come to the center evenly.
- (6) Receive the green raster, shift the deflection yoke from a foremost position (hitting against the picture tube) to a backward position horizontally, stop the deflection yoke at a position where it begins to become a green raster, and perform accurate marking on the picture tube.
- (7) Shift the deflection yoke further backward, and perform accurate marking at a position where the green raster begins to being luck.
- (8) Fix the deflection yoke at a position 60% forward within the range marked in items (6) and (7) above.

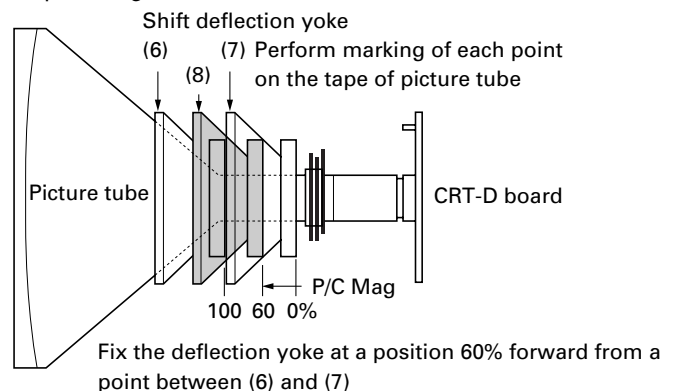

CONVERGENCE ADJUSTMENTS

* Adjust the convergence magnet to get vest convergence in the the order to (1) ~ (5).

■ CENTER CONVERGENCE:

- (1) Receive the white crosshatch or dot pattern from the service signal generator.
- (2) Use the 2 pieces of main 4-pole magnets of P/C magnets, change the open angle, and align the red and blue vertical lines on the screen center.
- (3) Freeze the open angle of the main 4-pole magnets, turn them simultaneously, and align the horizontal lines.
- (4) Take the same steps for items (2) and (3) above and align red/blue with green on the screen center using two 6-pole magnets.

(5) Adjust the sub-4-pole magnets only in case there is any deviation of Xv bow-shaped convergence. (To be usually set at the initial position)
Align both sides with the sub-4-pole magnets and minimize the deviation of blue and red with the main 4-pole magnets.

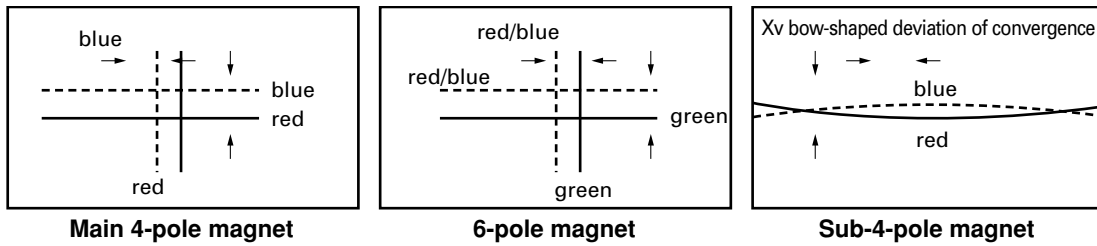

■ CIRCUMFERENCE CONVERGENCE:

* Perform correction in the following manner.

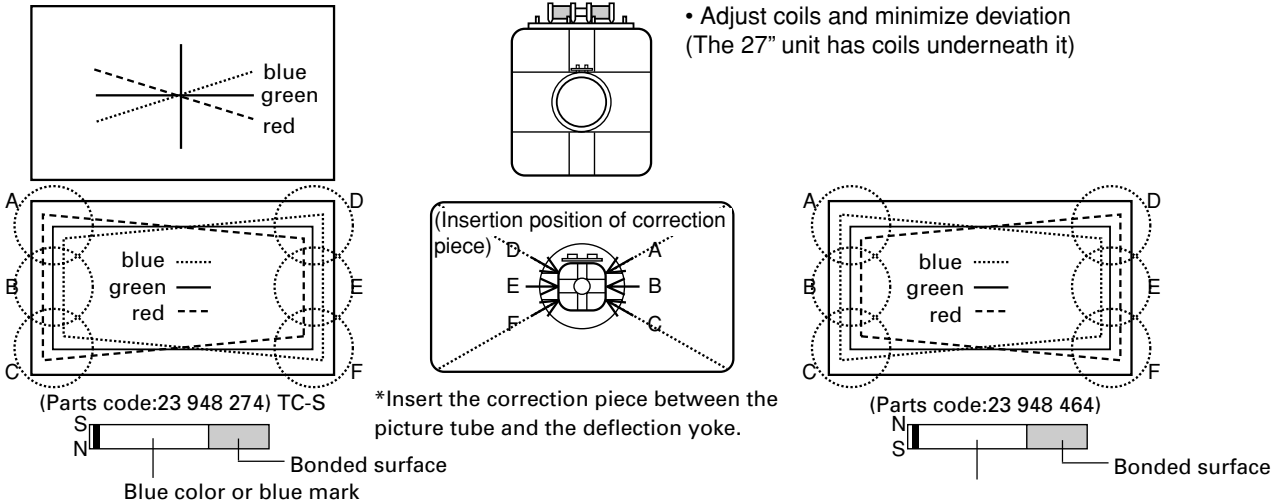

• Adjust coils and minimize deviation
(The 27" unit has coils underneath it)

Adjust VR 1 and minimize the deviation of YH. *Only 27", 30" and 32".

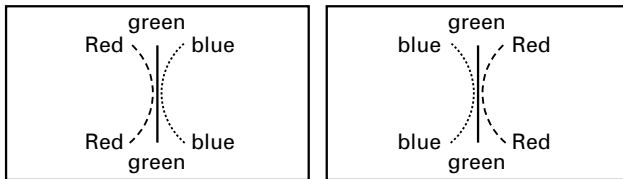

Adjust VR 2 (YHC) and minimize the deviation of YH.

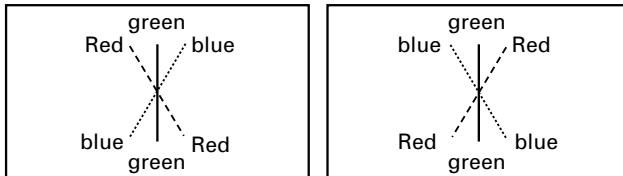

Adjust VR 3 (YV) and minimize the deviation of YV.

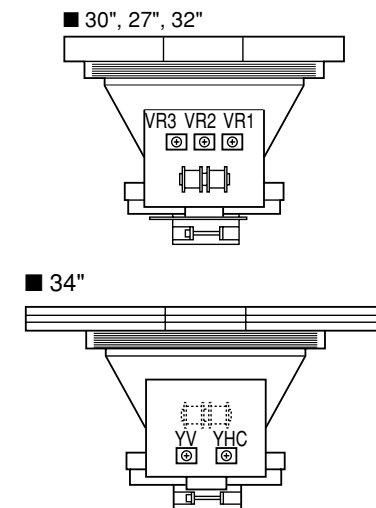
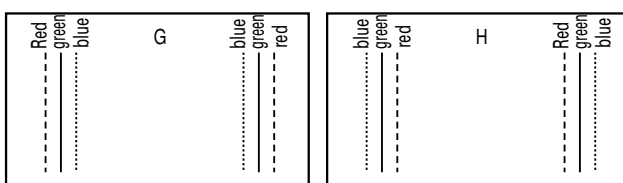
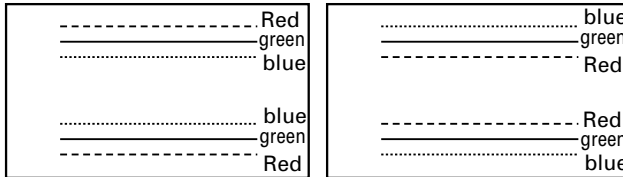

27" (Part No. 23 947 371)
32", 30" (Part No. 23 947 121)
34" (Part No. 23 993 080)

Perform correction by inserting the correction piece into the clearance of terminal board coils of the deflection yoke.

Note:
Perform insertion by turning the metal side to the terminal board side of the deflection yoke.

SERVICE MODE

1. ENTERING TO SERVICE MODE

- 1) Press MUTE button once on Remote Control.
- 2) Press MUTE button again to keep pressing.
- 3) While pressing the MUTE button, press MENU button on TV set.

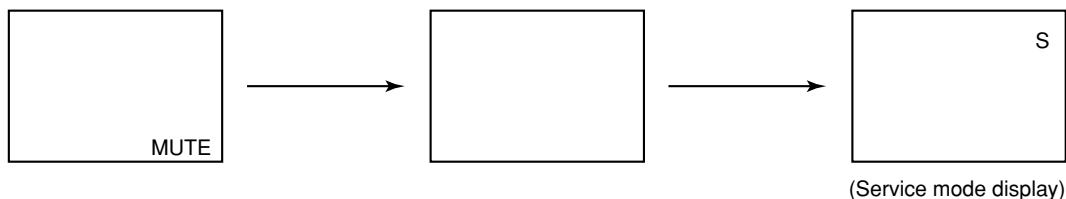

2. DISPLAYING THE ADJUSTMENT MENU

- 1) Press MENU button on TV.

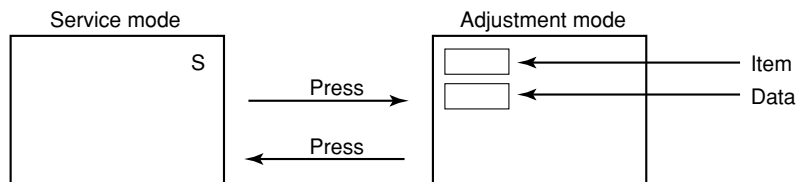

3. KEY FUNCTION IN THE SERVICE MODE

The following key entry during display of adjustment menu provides special functions.

A single horizontal line ON/OFF:	TV (ANT)/VIDEO button (on TV)
Test signal selection :	TV (ANT)/VIDEO button (on Remote)
Selection of the adjustment items :	Channel ▲/▼ (on TV or Remote)
Change of the data value :	Volume ◀/▶ (on TV or Remote)
Adjustment menu mode ON/OFF :	MENU button (on TV)
Initialization of the memory (QA02) :	RECALL+Channel (▲) button on TV
Initialization of the self diagnostic data:	RECALL+Channel (▼) button on TV

"RCUT" selection :	1 button
"GCUT" selection :	2 button
"BCUT" selection :	3 button
"CNTX" selection :	4 button
"COLC" selection :	5 button
"TNTC" selection :	6 button
Test audio signal ON/OFF (1kHz):	8 button
Self diagnostic display ON/OFF :	9 button

4. SELECTING THE ADJUSTING ITEMS

- 1) Every pressing of CHANNEL ▲ button in the service mode changes the adjustment items in the order of table-2. (▼ button for reverse order)

Refer to table-2 for preset data of adjustment mode.
(See SETTING & ADJUSTING DATA on page 13)

5. ADJUSTING THE DATA

- 1) Pressing of VOLUME ◀/▶ button will change the value of data in the range from 00H to FFH. The variable range depends on the adjusting item.

6. EXIT FROM SERVICE MODE

- 1) Pressing POWER button to turn off the TV once.

■ INITIALIZATION OF MEMORY DATA OF QA02

After replacing QA02, the following initialization is required.

1. Enter the service mode, then select any register item.
2. Press and hold the CALL button on the Remote, then press the CHANNEL ▲ button on the TV. The initialization of QA02 has been completed.
3. Check the picture carefully. If necessary, adjust any adjustment item above.
Perform "Auto search Memory" on the owner's manual.

CAUTION: Never attempt to initialize the data unless QA02 has been replaced.

7. TEST SIGNAL SELECTION

- 1) Every pressing of TV/VIDEO button on the Remote Control in the Service mode changes the built-in test patterns on screen in the following order.

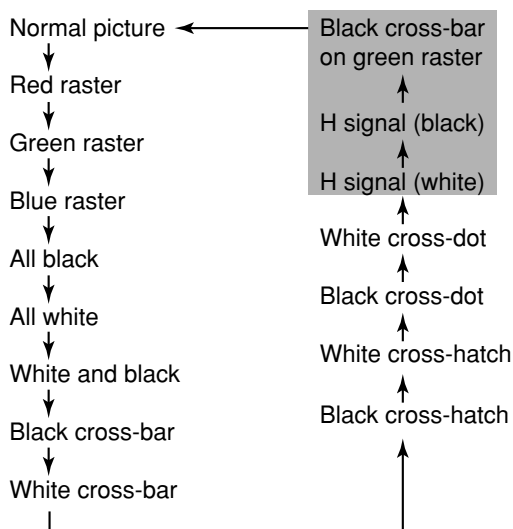

- 2) Press "8" button while any built-in test pattern to on the screen to output the 1 kHz sound. Press the button again to cut off the sound.

Note: If the video cable is connected to the VIDEO1 INPUT jack, the built-in pattern signals are not displayed.

Signals	Picture
<ul style="list-style-type: none"> • Red raster • Green raster • Blue raster • All Black • All White 	
<ul style="list-style-type: none"> • Black & White 	
<ul style="list-style-type: none"> • Black cross-bar • White cross-bar • Black cross-bar on green raster 	
<ul style="list-style-type: none"> • Black cross-hatch • White cross-hatch 	
<ul style="list-style-type: none"> • Black cross-dot • White cross-dot 	
<ul style="list-style-type: none"> • H signal (white) • H signal (black) 	

* The signals marked with ■ are not usable to display in the Test signal for some model.

8. SELF DIAGNOSTIC FUNCTION

- 1) Press "9" button on Remote Control during display of adjustment menu in the service mode.
The diagnosis will begin to check if interface among IC's are executed properly.
- 2) During diagnosis, the following displays are shown.

SELF CHECK	
①	NO. 23*****
②	POWER : 000
③	BUS LINE : OK
④	BUS CONT : OK
⑤	BLOCK : MAIN
⑥	SET ID : 03
⑦	E2P VER : 02
⑧	OPT0 : 20H OPT1 : 84H OPT2 : 01H

- ① Part number of microprocessor (QA01)
- ② Operation number of protection circuit (current limiter) . . . "000" is normal.
- ③ BUS line check
 - "OK" Normal
 - "SCL-GND" or "NG" SCL-GND short circuit
 - "SDA-GND" or "NG" SDA-GND short circuit
 - "SCL-SDA" or "NG" SCL-SDA short circuit
- ④ BUS line ACK (acknowledge) check
 - "OK" Normal
 - Display of Location Number . . . NG
 - (Display example)
 - "QA02 NG", "H001 NG", "Q501 NG" etc.
 - Note: The indication of failure place is only one place though failure places are plural. When repair of a failure place finishes, the next failure place is indicated. (The order of priority of indication is left side.)
- ⑤ SYNC signal available/not available (available: green, not available: red)
- ⑥ SET ID
- ⑦ Version of E2P
- ⑧ OPT data

* The item marked with ■ are not usable to display in the SELF DIAGNOSTIC FUNCTION for some model.

DESIGN MODE

1. ENTERING TO DESIGN MODE

- 1) Select the Service mode.
- 2) While pressing RECALL button on Remote and press MENU button on TV.
- 3) Press MENU button on TV.

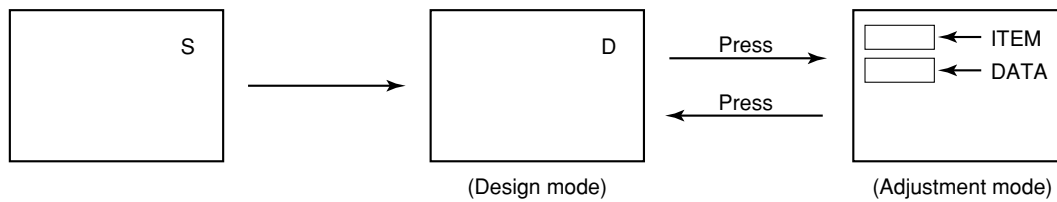

When QA02 is initialized, items "OPT0" and "OPT1" of DESIGN MODE are set to the data of the representative model of this chassis family.

Therefore, because ON-SCREEN specification remains in the state of the representative of model. This model is required to reset the data of items "OPT0" and "OPT1".

2. SELECTING THE ADJUSTING ITEMS

Every pressing of CHANNEL ▼ button in the design mode changes the adjustment items in the order of table-3. (▲ button for reverse order)

Refer to table-3 for data of design mode.
(See SETTING & ADJUSTING DATA on page 13)

3. ADJUSTING THE DATA

Pressing of VOLUME ▲ or ▼ button will change the value of data.

ELECTRICAL ADJUSTMENT

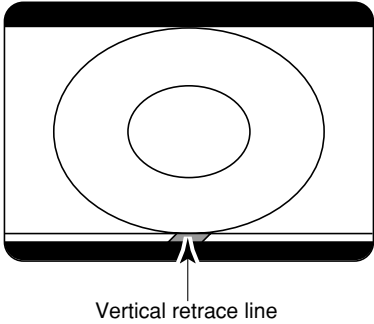
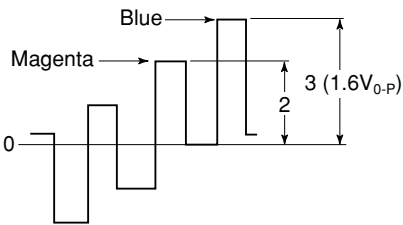
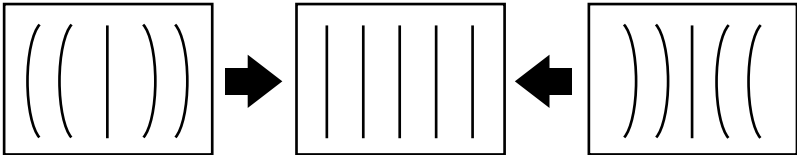
ITEM	ADJUSTMENT PROCEDURE
FOCUS VR ADJ	<ol style="list-style-type: none"> 1. Enter the service mode, then select any register item. 2. Press the TV/VIDEO button on the Remote until the black cross-bar pattern appears on the screen. 3. Adjust the FOCUS control (on T461) for well defined scanning lines on the picture screen.
SUB-BRIGHTNESS (BRTC)	<ol style="list-style-type: none"> 1. Constrict the picture height until the vertical retrace line appears adjusting the item HIT (HEIGHT). 2. Adjust the CONTRAST control to the minimum. 3. Call up the adjustment mode display, then select the item BRTC. 4. Press the VOLUME ▲ or ▼ button so the belt of vertical retrace line just disappear. 5. Adjust the CONTRAST control for the desired contrast. 6. Perform the HEIGHT adjustment. 
SUB-COLOR (SCOL) SUB-TINT (TNTC)	<ol style="list-style-type: none"> 1. Receive color-bar signal from color-bar generator. 2. Press the RESET button. 3. Connect oscilloscope to TP501 on SIGNAL board. 4. Adjust the CONTRAST control to the minimum. 5. Call up the adjustment mode display, then select the item TNTC. 6. Adjust the SUB-TINT by pressing the VOLUME ▲ or ▼ button to obtain a blue bar to magenta bar ratio of 3:2 as shown. 7. Press the RESET button. 8. Select the item SCOL. 9. Adjust the SUB-COLOR by pressing the VOLUME ▲ or ▼ button to achieve 1.6V_{0-P} of a blue bar on scope. 10. Check the picture with off-air signal. 
WIDTH (WID)	<ol style="list-style-type: none"> 1. Call up the adjustment mode display, then select the item WID. 2. Press the VOLUME ▲ or ▼ button to get the picture so the left and right edges of raster begins to lack. 3. Press the VOLUME ▲ or ▼ button to advance the data by 7 steps. <p>Note : Check the horizontal picture position is correct.</p>
E-W PARABOLA (DPC) (PARA)	<ol style="list-style-type: none"> 1. Call up the adjustment mode display, then select the item PARA. 2. Press the TV/VIDEO button on Remote until the cross-hatch pattern appears on the screen. 3. Press the VOLUME ▲ or ▼ button to make vertical lines straight as shown below. 

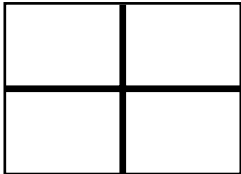
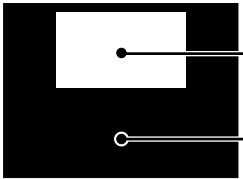
ITEM	ADJUSTMENT PROCEDURE																		
HORIZONTAL POSITION (HPOS) VERTICAL POSITION (VPOS)	<ol style="list-style-type: none"> 1. Call up the adjustment mode display, then select the item HPOS or VPOS. 2. Press the TV/VIDEO button on Remote until the white cross-bar or black cross-bar pattern appears on the screen. 3. Adjust the HORIZONTAL and VERTICAL position alternately by pressing the VOLUME ▲ or ▼ button for proper picture position. 4. Check the picture with off-air signal. 																		
HEIGHT (HIT)	<ol style="list-style-type: none"> 1. Call up the adjustment mode display, then select the item HIT. 2. Press the VOLUME ▲ or ▼ button to get the picture so the top of raster begins to lack. 3. Press the VOLUME ▲ button to advance the data by 9 steps. Note : Check the vertical picture position is correct.																		
WHITE BALANCE (RCUT) (GCUT) (BCUT) (GDRV) (BDRV)	<ol style="list-style-type: none"> 1. Adjust the CONTRAST control to the center, and BRIGHTNESS control to the maximum. 2. Call up the adjustment mode display, and press the TV/VIDEO button on Remote until the white and black pattern appears on the screen. 3. Adjust the following items with the CHANNEL ▲/▼ and VOLUME ▲/▼ buttons. <table style="margin-left: 40px; border: none;"> <tr> <td>Item : RCUT</td><td>→</td><td>Data : 40H</td> <td>Item : GDRV</td><td>→</td><td>Data : 40H</td> </tr> <tr> <td>Item : GCUT</td><td>→</td><td>Data : 40H</td> <td>Item : BDRV</td><td>→</td><td>Data : 40H</td> </tr> <tr> <td>Item : BCUT</td><td>→</td><td>Data : 40H</td> <td></td><td></td><td></td> </tr> </table> 4. Press the TV/VIDEO button on TV to display a single horizontal line on the screen. 5. Turn the SCREEN control (FBT) fully counterclockwise and gradually rotate clockwise until the first horizontal line appears slightly on the screen. 6. Press the TV/VIDEO button to display the normal picture. 7. Adjust the remaining two "?CUT" items (CHANNEL ▲/▼ → TV/VIDEO → VOLUME ▲/▼ in order) to obtain the slightly lighted horizontal line in the same levels of three (red, green, blue) colors. The line should be white if the adjustments are proper. 	Item : RCUT	→	Data : 40H	Item : GDRV	→	Data : 40H	Item : GCUT	→	Data : 40H	Item : BDRV	→	Data : 40H	Item : BCUT	→	Data : 40H			
Item : RCUT	→	Data : 40H	Item : GDRV	→	Data : 40H														
Item : GCUT	→	Data : 40H	Item : BDRV	→	Data : 40H														
Item : BCUT	→	Data : 40H																	

MTS ADJUSTMENT

No.	ITEM	INPUT SIGNAL	ADJUSTMENT PROCEDURE
1	ATTENUATOR (ATT)	<ul style="list-style-type: none"> • 1kHz 30% mod. → ANT terminal 	<ol style="list-style-type: none"> 1. Display item ATT on screen. 2. Connect a millivolt meter to TV OUT L of Monitor output terminal to observe the voltage. 3. Change data by VOLUME ▲/▼ buttons so that the reading of meter becomes value as close as 150mVrms.
2	STEREO SEPARATION (WBAN)	<ul style="list-style-type: none"> • STEREO 300Hz (30% mod.) R-channel only → ANT 	<ol style="list-style-type: none"> 1. Display item WBAN on screen. 2. Observe the waveform of TV OUT L of Monitor output terminal by an oscilloscope. 3. Change data by VOLUME ▲/▼ buttons so that 300Hz element on scope becomes minimum.
	(SPEC)	<ul style="list-style-type: none"> • STEREO 3kHz (30% mod.) R-channel only → ANT 	<ol style="list-style-type: none"> 1. Display item SPEC on screen. 2. Observe the waveform of TV OUT L of Monitor output terminal by an oscilloscope. 3. Change data by VOLUME ▲/▼ buttons so that 3KHz element on scope becomes minimum. Make the above adjustments so that the separation becomes optimum.

CIRCUIT CHECKS

HIGH VOLTAGE CHECK

CAUTION: There is no HIGH VOLTAGE ADJUSTMENT on this chassis. Checking should be done following the steps below.

1. Connect an accurate high voltage meter to the second anode of the picture tube.
2. Turn on the receiver. Set the BRIGHTNESS and CONTRAST controls to minimum (zero beam current).
3. High voltage must be measured below (B) kV.

Refer to table-1 for high voltage (B).
(See SETTING & ADJUSTING DATA on page 13)

4. Vary the BRIGHTNESS control to both extremes to be sure the high voltage does not exceed the limit under any conditions.

FS CIRCUIT CHECK

The Fail Safe (FS) circuit check is indispensable for the final check in servicing. Checking should be done following the steps below.

1. Turn the receiver on and press the RESET button.
2. Temporarily short TP-(R) and TP-(X) with a jumper wire. Raster and sound will disappear.
3. The receiver must remain in this state even after removing the jumper wire. This is the evidence that the FS circuit is functioning properly.
4. To obtain a picture again, temporarily turn the receiver off and allow the FS circuit more than 5 seconds to reset. Then turn the power switch on to produce a normal picture.

Troubleshooting Guide for Fail Safe Circuit

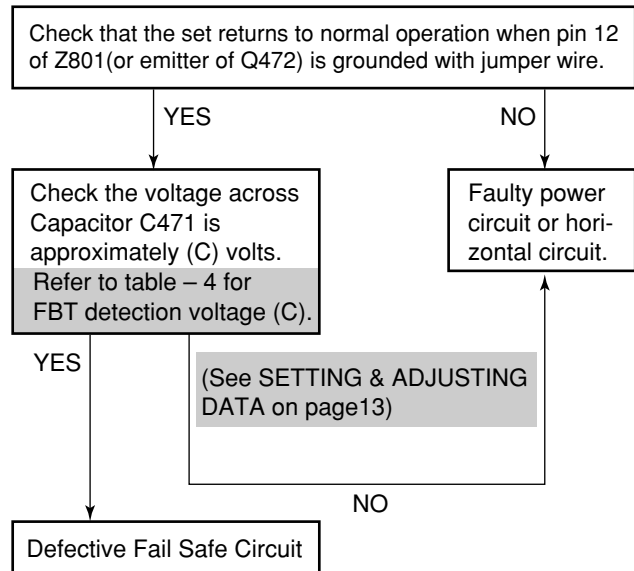

CHAPTER 2 SPECIFIC INFORMATIONS

SETTING & ADJUSTING DATA

【 SAFETY INSTRUCTIONS 】

		36"
HIGH VOLTAGE AT ZERO BEAM:	(A)	32.0kV
MAX HIGH VOLTAGE:	(B)	34.0kV

Table-1

【 SERVICE MODE 】

ADJUSTING ITEMS AND DATAS IN THE SERVICE MODE:

Item	Name of adjustment	Preset	Data	Item	Name of adjustment	Preset	Data
RCUT	R CUTOFF	40H	←	WBAN	STEREO SEPARATION	20H	16H
GCUT	G CUTOFF	40H	←	HPOS	HORIZ. POSITION	16H	19H
BCUT	B CUTOFF	40H	←	VPOS	VERT. POSITION	03H	←
GDRV	G DRIVE	40H	←	HIT	HEIGHT	26H	1CH
BDRV	B DRIVE	40H	←	LIN	V-LINEARITY	07H	←
SCNT	SUB-CONTRAST	0AH	09H	VSC	V-S CORRECTION	02H	03H
BRTC	SUB-BRIGHT	40H	43H	WID	PICTURE WIDTH	35H	25H
COLC	SUB-COLOR	3AH	3DH	DPC	E-W PARABOLA (DPC)	17H	13H
TNTC	SUB-TINT	44H	48H	CNR	E-W CORNER	09H	03H
SAVC	SAP VCO	20H	25H	TRAP	TRAPEZIUM	08H	07H
ATT	ATTENUATOR	20H	0FH	VPS	V-SHIFT	01H	←
STVC	STEREO VCO	20H	21H	VCP	V-COMPENSATION	03H	←
STRF	STEREO FILTER	20H	21H	HCP	H-COMPENSATION	00H	←
SPEC	SPECTRAL	20H	1DH	VFC	V-F CORRECTION	0FH	←

Table-2

【 DESIGN MODE 】

ADJUSTING ITEMS AND DATAS IN THE DESIGN MODE:

Item	Name of adjustment	Preset Data	Data	Remarks
OPT0	OPTION0	20H	20H	
OPT1	OPTION1	84H	84H	
OPT2	OPTION2	01H	01H	

Table-3

【 CIRCUIT CHECKS 】

FBT DETECTION VOLTAGE	(C)	22.3 V
-----------------------	-----	--------

Table-4

LOCATION OF CONTROLS

Front Control

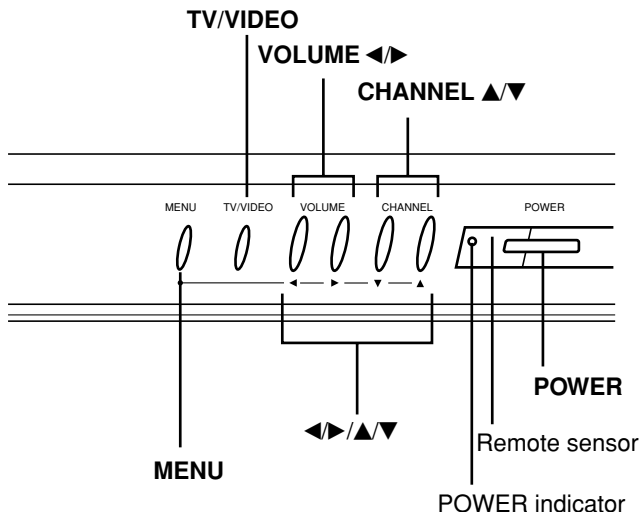

Back Term.

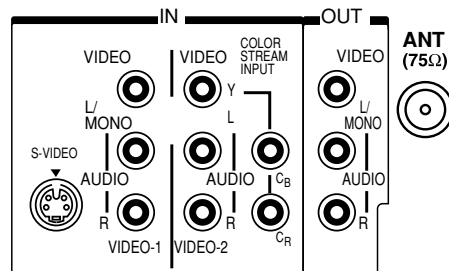

Remote Control

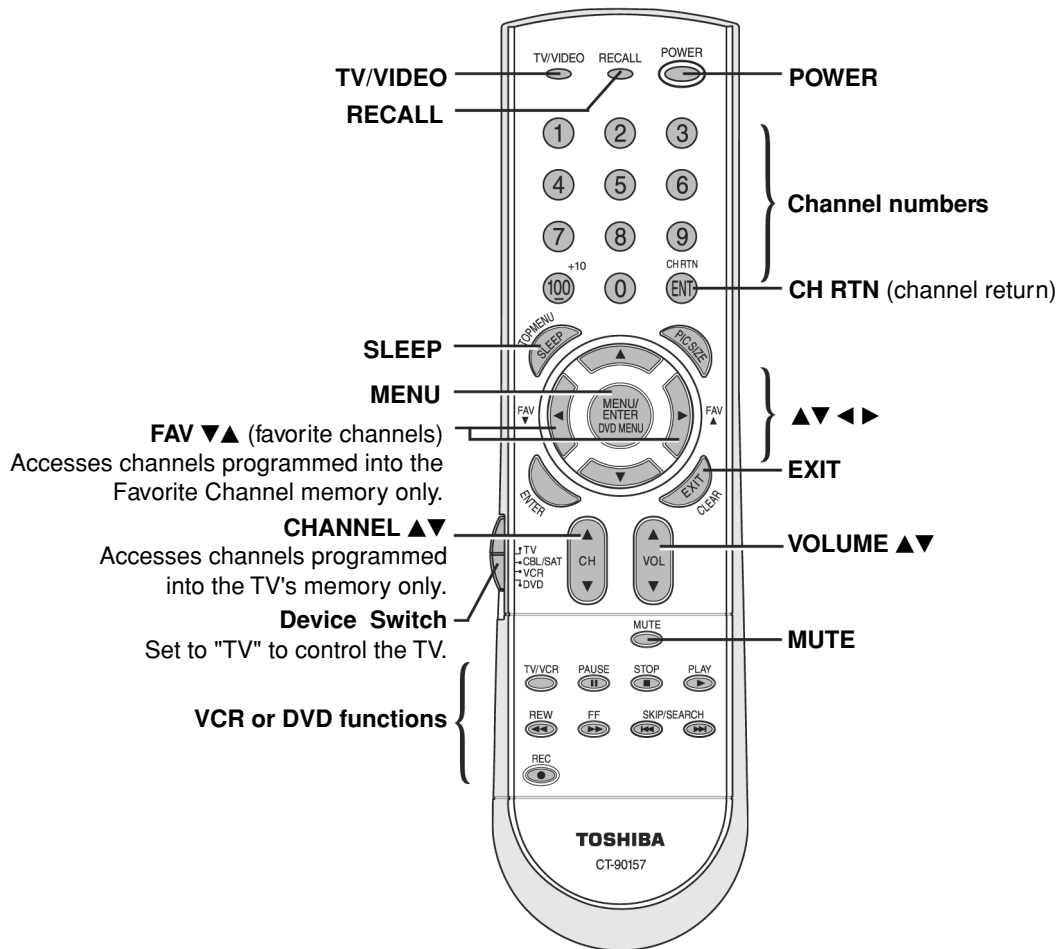

PROGRAMMING CHANNELS INTO THE TV'S MEMORY

When you press **CHANNEL ▲ ▼** on the TV or remote control, the TV stops only on the channels stored in the TV's memory. **Note:** To tune the TV to a channel not programmed into the memory, use the **CHANNEL NUMBERS** on the remote control. Follow the steps below to program channels into the TV's memory.

Programming channels automatically

Your TV can automatically detect all active channels in your area and store them in the TV's memory. After the channels are stored automatically, you can manually add or erase individual channels.

To program channels automatically:

- 1 Press **MENU**.
- 2 Press **◀** or **▶** to highlight the SET UP menu.
- 3 Press **▲** or **▼** to highlight TV/CABLE.
- 4 Press **◀** or **▶** to highlight TV (if you use an antenna) or CABLE (if you use cable).
- 5 Press **▼** to highlight CH PROGRAM.
- 6 Press **◀** or **▶** to start automatic channel programming ("CH PROGRAM" displays on-screen). The TV automatically cycles through every TV or cable channel (depending on which you selected), and stores all active channels in the TV's memory.
- 7 When automatic channel programming is complete, the message "CH Programming Completed" appears.
- 8 Press **CHANNEL ▲ ▼** to view the programmed channels.

Adding and erasing channels manually

After you have automatically programmed the channels into the TV's memory, you can manually add and erase individual channels.

To add a channel to or erase a channels from the TV's memory:

- 1 Tune the TV to the channel you want to add or erase. If you are adding a channel, you will need to use the **CHANNEL NUMBERS** to select the channel.
- 2 Press **MENU**.
- 3 Press **◀** or **▶** to highlight the SET UP menu.
- 4 Press **▲** or **▼** to highlight ADD/ERASE.
- 5 Press **◀** or **▶** to highlight ADD or ERASE, whichever function you want to perform.
- 6 Press **MENU**.
- 7 Repeat steps 1-6 for other channels you want to add or erase, or press **EXIT** to return to normal TV viewing.

Changing channels:

To change to the next programmed channel:
Press **CHANNEL ▲ ▼**.

To change to a specific channel (programmed or unprogrammed):

Press the **CHANNEL NUMBERS** (0-9 and 100).

Note: For channels 100 and higher, press the 100 button, and then the next two channel numbers (for example, to select channel 100, press 100, 0, 0; to select channel 125, press 100, 2, 5).

CHASSIS AND CABINET REPLACEMENT PARTS LIST

WARNING: BEFORE SERVICING THIS CHASSIS, READ THE "X-RAY RADIATION PRECAUTION", "SAFETY PRECAUTION" AND "PRODUCT SAFETY NOTICE" ON PAGE 3 OF THIS MANUAL.

CAUTION: The international hazard symbols "" in the schematic diagram and the parts list designate components which have special characteristics important for safety and should be replaced only with types identical to those in the original circuit or specified in the parts list. The mounting position of replacements is to be identical with originals. Before replacing any of these components, read carefully the PRODUCT SAFETY NOTICE. Do not degrade the safety of the receiver through improper servicing.

NOTICE:

- The part number must be used when ordering parts, in order to assist in processing, be sure to include the Model number and Description.
- The PC board assembly with * mark is no longer available after the end of the production.

Model : 36A43

Capacitors CD : Ceramic Disk PF : Plastic Film EL : Electrolytic
 Resistors CF : Carbon Film CC : Carbon Composition MF : Metal Film
 OMF : Oxide Metal Film VR : Variable Resistor FR : Fusible Resistor

(All CD and PF capacitors are $\pm 5\%$, 50V and all resistors, $\pm 5\%$, 1/6W unless otherwise noted.)

Location No.	Parts No.	Description
CAPACITORS		
C102	24792471	ELECTROLYTIC, 6.3V 470UF M
C105	24212102	CERAMIC DISC, 50V B 1000PF K
C106	24797479	ELECTROLYTIC, 50V 4.7UF M
C107	24763221	ELECTROLYTIC, 16V 220UF M
C201	24539104	PLASTIC FILM, 50V 0.1UF J
C204	24797010	ELECTROLYTIC, 50V 1UF M
C205	24794100	ELECTROLYTIC, 16V 10UF M
C216	24794100	ELECTROLYTIC, 16V 10UF M
C220	24539474	PLASTIC FILM, 50V 0.47UF J
C221	24109103	CERAMIC CHIP, 50V B 0.01UF K
C222	24109103	CERAMIC CHIP, 50V B 0.01UF K
C223	24109103	CERAMIC CHIP, 50V B 0.01UF K
C224	24539104	PLASTIC FILM, 50V 0.1UF J
C225	24539104	PLASTIC FILM, 50V 0.1UF J
C226	24539104	PLASTIC FILM, 50V 0.1UF J
C245	24206108	ELECTROLYTIC, 50V 0.1UF M 7L 3A
C261	24539104	PLASTIC FILM, 50V 0.1UF J
C262	24539104	PLASTIC FILM, 50V 0.1UF J
C263	24539104	PLASTIC FILM, 50V 0.1UF J
C271	24109561	CERAMIC CHIP, 50V B 560PF K
C305	24617912	ELECTROLYTIC, 50V 2.2UF K 3A LI
C306	24764222	ELECTROLYTIC, 25V 2200UF M
C307	24082272	PLASTIC FILM, 100V 0.047UF J
C308	24668221	ELECTROLYTIC, 35V 220UF M 3A
C309	24109102	CERAMIC CHIP, 50V B 1000PF K
C310	24766102	ELECTROLYTIC, 50V 1000UF M
C311	24214102	CERAMIC DISC, 500V B 1000PF K
C313	24082057	PLASTIC FILM, 100V 0.22UF J
C314	24591222	PLASTIC FILM, 50V 2200PF J
C317	24214471	CERAMIC DISC, 500V B 470PF K
C318	24109102	CERAMIC CHIP, 50V B 1000PF K
C319	24109102	CERAMIC CHIP, 50V B 1000PF K
C320	24797101	ELECTROLYTIC, 50V 100UF M
C323	24539474	PLASTIC FILM, 50V 0.47UF J
C325	24539683	PLASTIC FILM, 50V 0.068UF J
C326	24539104	PLASTIC FILM, 50V 0.1UF J
C327	24617915	ELECTROLYTIC, 50V 1UF K 3A LI
C337	24797229	ELECTROLYTIC, 50V 2.2UF M

Location No.	Parts No.	Description
C370	24794101	ELECTROLYTIC, 16V 100UF M
C371	24794100	ELECTROLYTIC, 16V 10UF M
C403	24539103	PLASTIC FILM, 50V 0.01UF J
C404	24797010	ELECTROLYTIC, 50V 1UF M
C407	24539104	PLASTIC FILM, 50V 0.1UF J
C412	24214472	CERAMIC DISC, 500V B 4700PF K
C413	24214821	CERAMIC DISC, 500V B 820PF K
C415	24539224	PLASTIC FILM, 50V 0.22UF J
C416	24678010	ELECTROLYTIC, 200V 1UF M 3A
C417	24214331	CERAMIC DISC, 500V B 330PF K
C421	24539334	PLASTIC FILM, 50V 0.33UF J
C430	24109103	CERAMIC CHIP, 50V B 0.01UF K
C431	24794101	ELECTROLYTIC, 16V 100UF M
C438	24092344	CERAMIC DISC, 2KV 820PF K
C439	24503125	PLASTIC FILM, 400V 0.075UF J
C442	24503305	PLASTIC FILM CF92 T 315V R62UF J
C443	24503272	PLASTIC FILM, 1500VH 7200PF H
C444	24503194	PLASTIC FILM, 1500VH 0.01UF H
C445	24082050	PLASTIC FILM, 100V 0.056UF J
C446	24679100	ELECTROLYTIC, 250V 10UF M 3A
C448	24073118	ELECTROLYTIC, 160V 33UF M
C449	24794102	ELECTROLYTIC, 16V 1000UF M
C453	24539334	PLASTIC FILM, 50V 0.33UF J
C457	24591222	PLASTIC FILM, 50V 2200PF J
C463	24212152	CERAMIC DISC, 50V B 1500PF K
C464	24640872	ELECTROLYTIC, 100V 10UF M 3A
C466	24567104	PLASTIC FILM, 50V 0.1UF J
C467	24503160	PLASTIC FILM, 630V 0.043UF J
C471	24797479	ELECTROLYTIC, 50V 4.7UF M
C474	24794100	ELECTROLYTIC, 16V 10UF M
C477	24539104	PLASTIC FILM, 50V 0.1UF J
C478	24539563	PLASTIC FILM, 50V 0.056UF J
C480	24747220	ELECTROLYTIC, 50V 22UF M 7L 3A
C481	24539474	PLASTIC FILM, 50V 0.47UF J
C482	24797478	ELECTROLYTIC, 50V 0.47UF M
C483	24206108	ELECTROLYTIC, 50V 0.1UF M 7L 3A
C499	24212102	CERAMIC DISC, 50V B 1000PF K
C501	24109102	CERAMIC CHIP, 50V B 1000PF K
C504	24591222	PLASTIC FILM, 50V 2200PF J

Location No.	Parts No.	Description
C505	24105130	CERAMIC CHIP, 50V CH 13PF J
C510	24109103	CERAMIC CHIP, 50V B 0.01UF K
C511	24794101	ELECTROLYTIC, 16V 100UF M
C512	24206228	ELECTROLYTIC, 50V 0.22UF M 7L 3A
C582	24109103	CERAMIC CHIP, 50V B 0.01UF K
C583	24762471	ELECTROLYTIC, 10V 470UF M
C612	24794470	ELECTROLYTIC, 16V 47UF M
C613	24109103	CERAMIC CHIP, 50V B 0.01UF K
C661	24212102	CERAMIC DISC, 50V B 1000PF K
C662	24212102	CERAMIC DISC, 50V B 1000PF K
C663	24794100	ELECTROLYTIC, 16V 10UF M
C664	24796101	ELECTROLYTIC, 35V 100UF M
C671	24667470	ELECTROLYTIC, 25V 47UF M 3A
C672	24667470	ELECTROLYTIC, 25V 47UF M 3A
C673	24797229	ELECTROLYTIC, 50V 2.2UF M
C676	24503041	PLASTIC FILM, 63V 0.1UF J
C677	24503041	PLASTIC FILM, 63V 0.1UF J
C678	24797229	ELECTROLYTIC, 50V 2.2UF M
C679	24667470	ELECTROLYTIC, 25V 47UF M 3A
C681	24795102	ELECTROLYTIC, 25V 1000UF M
C683	24795102	ELECTROLYTIC, 25V 1000UF M
△ C801	24503002	PLASTIC FILM, AC275V 0.22UF M
△ C802	24503001	PLASTIC FILM, AC275V 0.1UF M
C805	24092623	CERAMIC DISC, 250V F 0.01UF Z
C806	24092623	CERAMIC DISC, 250V F 0.01UF Z
C808	24797470	ELECTROLYTIC, 50V 47UF M
C810	24086061	ELECTROLYTIC, 200V 470UF M 3F
△ C815	24092583	CERAMIC DISC, AC250V E 2200PF M
C817	24092339	CERAMIC DISC, 2KV 330PF K
C818	24082402	PLASTIC FILM, 1250VH 2200PF H
C819	24795221	ELECTROLYTIC, 25V 220UF M
C821	24214471	CERAMIC DISC, 500V B 470PF K
△ C822	24092583	CERAMIC DISC, AC250V E 2200PF M
△ C823	24092583	CERAMIC DISC, AC250V E 2200PF M
C825	24212471	CERAMIC DISC, 50V B 470PF K
C829	24590182	PLASTIC FILM, 50V 1800PF J
C832	24539334	PLASTIC FILM, 50V 0.33UF J
C840	24797010	ELECTROLYTIC, 50V 1UF M
C842	24792101	ELECTROLYTIC, 6.3V 100UF M
C884	24640018	ELECTROLYTIC, 160V 220UF
C885	24214471	CERAMIC DISC, 500V B 470PF K
C889	24796222	ELECTROLYTIC, 35V 2200UF M
C893	24092339	CERAMIC DISC, 2KV 330PF K
C898	24539474	PLASTIC FILM, 50V 0.47UF J
C902	24092345	CERAMIC DISC, 2KV 1000PF K
C904	24436391	CERAMIC DISC, 50V SL 390PF J
C905	24436391	CERAMIC DISC, 50V SL 390PF J
C906	24436391	CERAMIC DISC, 50V SL 390PF J
C909	24679220	ELECTROLYTIC, 250V 22UF M 3A
C910	24797478	ELECTROLYTIC, 50V 0.47UF M
C911	24794100	ELECTROLYTIC, 16V 10UF M
C912	24763471	ELECTROLYTIC, 16V 470UF M
C913	24794100	ELECTROLYTIC, 16V 10UF M
C914	24232103	CERAMIC DISC, 50V F 0.01UF Z
C920	24214101	CERAMIC DISC, 500V B 100PF K
CA32	24100104	CERAMIC CHIP, 25V F 0.1UF Z
CA37	24105101	CERAMIC CHIP, 50V CH 100PF J
CA38	24105101	CERAMIC CHIP, 50V CH 100PF J
CA42	24794100	ELECTROLYTIC, 16V 10UF M
CA43	24109103	CERAMIC CHIP, 50V B 0.01UF K
CA44	24109103	CERAMIC CHIP, 50V B 0.01UF K
CA68	24794100	ELECTROLYTIC, 16V 10UF M
CA69	24109103	CERAMIC CHIP, 50V B 0.01UF K
CB01	24794470	ELECTROLYTIC, 16V 47UF M
CB48	24105101	CERAMIC CHIP, 50V CH 100PF J

Location No.	Parts No.	Description
CB60	24085944	ELECTROLYTIC, NONPOLAR, 50V 2.2UF M 11L
CB61	24591102	PLASTIC FILM, 50V 1000PF J
CB62	24109561	CERAMIC CHIP, 50V B 560PF K
CB63	24109122	CERAMIC CHIP, 50V B 1200PF K
CB64	24763471	ELECTROLYTIC, 16V 470UF M
CB65	24100104	CERAMIC CHIP, 25V F 0.1UF Z
CG01	24794101	ELECTROLYTIC, 16V 100UF M
CG02	24794220	ELECTROLYTIC, 16V 22UF M
CG03	24539104	PLASTIC FILM, 50V 0.1UF J
CG04	24109103	CERAMIC CHIP, 50V B 0.01UF K
CG06	24797479	ELECTROLYTIC, 50V 4.7UF M
CG07	24797229	ELECTROLYTIC, 50V 2.2UF M
CG08	24109473	CERAMIC CHIP, 25V B 0.047UF K
CG09	24797478	ELECTROLYTIC, 50V 0.47UF M
CG10	24539104	PLASTIC FILM, 50V 0.1UF J
CG12	24206108	ELECTROLYTIC, 50V 0.1UF M 7L 3A
CG13	24088907	TA SOLID ELEC. CHIP, 16V 3.3UF M A-CAE
CG14	24797010	ELECTROLYTIC, 50V 1UF M
CG16	24088098	TA SOLID ELEC., 16V 10UF M B2-CA
CG17	24797010	ELECTROLYTIC, 50V 1UF M
CG18	24797010	ELECTROLYTIC, 50V 1UF M
CG19	24797479	ELECTROLYTIC, 50V 4.7UF M
CG20	24797010	ELECTROLYTIC, 50V 1UF M
CG25	24797479	ELECTROLYTIC, 50V 4.7UF M
CG26	24797479	ELECTROLYTIC, 50V 4.7UF M
CG27	24109223	CERAMIC CHIP, 25V B 0.022UF K
CG28	24797229	ELECTROLYTIC, 50V 2.2UF M
CG29	24591102	PLASTIC FILM, 50V 1000PF J
CG30	24206108	ELECTROLYTIC, 50V 0.1UF M 7L 3A
CG31	24797229	ELECTROLYTIC, 50V 2.2UF M
CG32	24591102	PLASTIC FILM, 50V 1000PF J
CG33	24206108	ELECTROLYTIC, 50V 0.1UF M 7L 3A
CG34	24797229	ELECTROLYTIC, 50V 2.2UF M
CG35	24797229	ELECTROLYTIC, 50V 2.2UF M
CG42	24797010	ELECTROLYTIC, 50V 1UF M
CG44	24794100	ELECTROLYTIC, 16V 10UF M
CI01	24109103	CERAMIC CHIP, 50V B 0.01UF K
CI02	24109103	CERAMIC CHIP, 50V B 0.01UF K
CI03	24109103	CERAMIC CHIP, 50V B 0.01UF K
CI04	24109103	CERAMIC CHIP, 50V B 0.01UF K
CI05	24109103	CERAMIC CHIP, 50V B 0.01UF K
CI07	24109103	CERAMIC CHIP, 50V B 0.01UF K
CI08	24797010	ELECTROLYTIC, 50V 1UF M
CI09	24105470	CERAMIC CHIP, 50V CH 47PF J
CI10	24105180	CERAMIC CHIP, 50V CH 18PF J
CI11	24105270	CERAMIC CHIP, 50V CH 27PF J
CI12	24797478	ELECTROLYTIC, 50V 0.47UF M
CI13	24109102	CERAMIC CHIP, 50V B 1000PF K
CI14	24105470	CERAMIC CHIP, 50V CH 47PF J
CI15	24105390	CERAMIC CHIP, 50V CH 39PF J
CI16	24109103	CERAMIC CHIP, 50V B 0.01UF K
CI17	24092726	CERAMIC CHIP CK733B 16V 2,200,000PFK
CI18	24105181	CERAMIC CHIP, 50V CH 180PF J
CI21	24109103	CERAMIC CHIP, 50V B 0.01UF K
CI23	24109103	CERAMIC CHIP, 50V B 0.01UF K
CI25	24105240	CERAMIC CHIP, 50V CH 24PF J
CI51	24797220	ELECTROLYTIC, 50V 22UF M
CI52	24794101	ELECTROLYTIC, 16V 100UF M
CI53	24797339	ELECTROLYTIC, 50V 3.3UF M
CM51	24539104	PLASTIC FILM, 50V 0.1UF J
CM52	24105331	CERAMIC CHIP, 50V CH 330PF J
CM58	24539104	PLASTIC FILM, 50V 0.1UF J
CR01	24100104	CERAMIC CHIP, 25V F 0.1UF Z
CR02	24100104	CERAMIC CHIP, 25V F 0.1UF Z

Location No.	Parts No.	Description
CR03	24100104	CERAMIC CHIP, 25V F 0.1UF Z
CS02	24797229	ELECTROLYTIC, 50V 2.2UF M
CS04	24797229	ELECTROLYTIC, 50V 2.2UF M
CS08	24797229	ELECTROLYTIC, 50V 2.2UF M
CS10	24797229	ELECTROLYTIC, 50V 2.2UF M
CS25	24617912	ELECTROLYTIC, 50V 2.2UF K 3A LI
CS26	24617912	ELECTROLYTIC, 50V 2.2UF K 3A LI
CS40	24797010	ELECTROLYTIC, 50V 1UF M
CS42	24797010	ELECTROLYTIC, 50V 1UF M
CS43	24109331	CERAMIC CHIP, 50V B 330PF K
CS44	24109331	CERAMIC CHIP, 50V B 330PF K
CS45	24109331	CERAMIC CHIP, 50V B 330PF K
CS46	24109331	CERAMIC CHIP, 50V B 330PF K
CS49	24109331	CERAMIC CHIP, 50V B 330PF K
CS50	24109331	CERAMIC CHIP, 50V B 330PF K
CS51	24109102	CERAMIC CHIP, 50V B 1000PF K
CS52	24109102	CERAMIC CHIP, 50V B 1000PF K
CS70	24794220	ELECTROLYTIC, 16V 22UF M
CS71	24794220	ELECTROLYTIC, 16V 22UF M
CV01	24797229	ELECTROLYTIC, 50V 2.2UF M
CV03	24206108	ELECTROLYTIC, 50V 0.1UF M 7L 3A
CV05	24109103	CERAMIC CHIP, 50V B 0.01UF K
CV07	24797229	ELECTROLYTIC, 50V 2.2UF M
CV09	24539104	PLASTIC FILM, 50V 0.1UF J
CV10	24109103	CERAMIC CHIP, 50V B 0.01UF K
CV11	24109103	CERAMIC CHIP, 50V B 0.01UF K
CV12	24539104	PLASTIC FILM, 50V 0.1UF J
CV27	24617912	ELECTROLYTIC, 50V 2.2UF K 3A LI
CV36	24794220	ELECTROLYTIC, 16V 22UF M
CV38	24763471	ELECTROLYTIC, 16V 470UF M
CV39	24109103	CERAMIC CHIP, 50V B 0.01UF K
CV41	24797229	ELECTROLYTIC, 50V 2.2UF M
CV60	24763471	ELECTROLYTIC, 16V 470UF M
CV61	24763471	ELECTROLYTIC, 16V 470UF M
CZ01	24794101	ELECTROLYTIC, 16V 100UF M
CZ02	24109103	CERAMIC CHIP, 50V B 0.01UF K
CZ03	24794100	ELECTROLYTIC, 16V 10UF M
CZ04	24105181	CERAMIC CHIP, 50V CH 180PF J
CZ05	24105680	CERAMIC CHIP, 50V CH 68PF J
CZ06	24105330	CERAMIC CHIP, 50V CH 33PF J
CZ08	24100104	CERAMIC CHIP, 25V F 0.1UF Z
CZ09	24109103	CERAMIC CHIP, 50V B 0.01UF K
CZ10	24794101	ELECTROLYTIC, 16V 100UF M
CZ12	24105101	CERAMIC CHIP, 50V CH 100PF J
CZ13	24105121	CERAMIC CHIP, 50V CH 120PF J
CZ14	24105151	CERAMIC CHIP, 50V CH 150PF J
CZ16	24105330	CERAMIC CHIP, 50V CH 33PF J
CZ28	24212122	CERAMIC DISC, 50V B 1200PF K
CZ29	24792101	ELECTROLYTIC, 6.3V 100UF M
CZ30	24100104	CERAMIC CHIP, 25V F 0.1UF Z
CZ31	24105100	CERAMIC CHIP, 50V CH 10PF D
CZ32	24100104	CERAMIC CHIP, 25V F 0.1UF Z
CZ33	24100104	CERAMIC CHIP, 25V F 0.1UF Z
CZ34	24794101	ELECTROLYTIC, 16V 100UF M
CZ35	24792101	ELECTROLYTIC, 6.3V 100UF M
CZ36	24792101	ELECTROLYTIC, 6.3V 100UF M
CZ37	24109103	CERAMIC CHIP, 50V B 0.01UF K
CZ39	24100104	CERAMIC CHIP, 25V F 0.1UF Z
CZ41	24109103	CERAMIC CHIP, 50V B 0.01UF K
CZ42	24792101	ELECTROLYTIC, 6.3V 100UF M
CZ43	24105181	CERAMIC CHIP, 50V CH 180PF J
CZ44	24100104	CERAMIC CHIP, 25V F 0.1UF Z
CZ45	24100104	CERAMIC CHIP, 25V F 0.1UF Z
CZ46	24100104	CERAMIC CHIP, 25V F 0.1UF Z
CZ47	24100104	CERAMIC CHIP, 25V F 0.1UF Z

Location No.	Parts No.	Description
CZ48	24109103	CERAMIC CHIP, 50V B 0.01UF K
CZ49	24105330	CERAMIC CHIP, 50V CH 33PF J
CZ50	24797229	ELECTROLYTIC, 50V 2.2UF M
CZ57	24105181	CERAMIC CHIP, 50V CH 180PF J
CZ58	24105560	CERAMIC CHIP, 50V CH 56PF J
CZ60	24105100	CERAMIC CHIP, 50V CH 10PF D

RESISTORS

R101	24553223	OXIDE METAL FILM, 1W 22K OHM J
R203	24011474	CHIP, METAL FILM, 1/20W 470K OHM J
R207	24011101	CHIP, METAL FILM, 1/20W 100 OHM J
R208	24011101	CHIP, METAL FILM, 1/20W 100 OHM J
R209	24011101	CHIP, METAL FILM, 1/20W 100 OHM J
R216	24011223	CHIP, METAL FILM, 1/20W 22K OHM J
R228	24553683	OXIDE METAL FILM, 1W 68K OHM J
R238	24011473	CHIP, METAL FILM, 1/20W 47K OHM J
R239	24011224	CHIP, METAL FILM, 1/20W 220K OHM J
R240	24011562	CHIP, METAL FILM, 1/20W 5.6K OHM J
R241	24011682	CHIP, METAL FILM, 1/20W 6.8K OHM J
R245	24366104	CARBON FILM, 1/6W 100K OHM J
R261	24011472	CHIP, METAL FILM, 1/20W 4.7K OHM J
R262	24011102	CHIP, METAL FILM, 1/20W 1K OHM J
R263	24011472	CHIP, METAL FILM, 1/20W 4.7K OHM J
R264	24011102	CHIP, METAL FILM, 1/20W 1K OHM J
R265	24011472	CHIP, METAL FILM, 1/20W 4.7K OHM J
R266	24011102	CHIP, METAL FILM, 1/20W 1K OHM J
R271	24366471	CARBON FILM, 1/6W 470 OHM J
R272	24011222	CHIP, METAL FILM, 1/20W 2.2K OHM J
R301	24011102	CHIP, METAL FILM, 1/20W 1K OHM J
R303	24321109	OXIDE METAL FILM, 1/2W 1 OHM J
R304	24011393	CHIP, METAL FILM, 1/20W 39K OHM J
R305	24322688	OXIDE METAL FILM, 1W 0.68 OHM J
R306	24366563	CARBON FILM, 1/6W 56K OHM J
R307	24011474	CHIP, METAL FILM, 1/20W 470K OHM J
R308	24382821	OXIDE METAL FILM, 1W 82 OHM J
R310	24011153	CHIP, METAL FILM, 1/20W 15K OHM J
R311	24011392	CHIP, METAL FILM, 1/20W 3.9K OHM J
R313	24011104	CHIP, METAL FILM, 1/20W 100K OHM J
R314	24011105	CHIP, METAL FILM, 1/20W 1M OHM J
R315	24011824	CHIP, METAL FILM, 1/20W 820K OHM J
R317	24011102	CHIP, METAL FILM, 1/20W 1K OHM J
R327	24339569	OXIDE METAL FILM, 2W 5.6 OHM J
R328	24011824	CHIP, METAL FILM, 1/20W 820K OHM J
R336	24383391	OXIDE METAL FILM, 2W 390 OHM J
R360	24011104	CHIP, METAL FILM, 1/20W 100K OHM J
R361	24011473	CHIP, METAL FILM, 1/20W 47K OHM J
R370	24321109	OXIDE METAL FILM, 1/2W 1 OHM J
R371	24011103	CHIP, METAL FILM, 1/20W 10K OHM J
R372	24011392	CHIP, METAL FILM, 1/20W 3.9K OHM J
R373	24011102	CHIP, METAL FILM, 1/20W 1K OHM J
R374	24366183	CARBON FILM, 1/6W 18K OHM J
R401	24011391	CHIP, METAL FILM, 1/20W 390 OHM J
R403	24011562	CHIP, METAL FILM, 1/20W 5.6K OHM J
R405	24382682	OXIDE METAL FILM, 1W 6.8K OHM J
R406	24366473	CARBON FILM, 1/6W 47K OHM J
R408	24011472	CHIP, METAL FILM, 1/20W 4.7K OHM J
R410	24011271	CHIP, METAL FILM, 1/20W 270 OHM J
R411	24366561	CARBON FILM, 1/6W 560 OHM J
R415	24553272	OXIDE METAL FILM, 1W 2.7K OHM J
R416	24510392	CERAMIC COVERED, 5W 3.9K OHM J
R418	24383181	OXIDE METAL FILM, 2W 180 OHM J
R429	24366104	CARBON FILM, 1/6W 100K OHM J
R430	24366102	CARBON FILM, 1/6W 1K OHM J
R431	24366103	CARBON FILM, 1/6W 10K OHM J
R432	24011222	CHIP, METAL FILM, 1/20W 2.2K OHM J

Location No.	Parts No.	Description
R441	24532102	FUSIBLE, 1W 1K OHM J
R448	24338478	OXIDE METAL FILM, 1W 0.47 OHM J
R455	24011103	CHIP, METAL FILM, 1/20W 10K OHM J
R457	24011104	CHIP, METAL FILM, 1/20W 100K OHM J
R460	24366562	CARBON FILM, 1/6W 5.6K OHM J
R461	24011102	CHIP, METAL FILM, 1/20W 1K OHM J
R463	24322479	OXIDE METAL FILM, 1W 4.7 OHM J
R464	24366102	CARBON FILM, 1/6W 1K OHM J
R465	24011332	CHIP, METAL FILM, 1/20W 3.3K OHM J
R466	24366103	CARBON FILM, 1/6W 10K OHM J
R467	24011474	CHIP, METAL FILM, 1/20W 470K OHM J
R472	24381270	OXIDE METAL FILM, 1/2W 27 OHM J
R473	24366473	CARBON FILM, 1/6W 47K OHM J
R474	24366184	CARBON FILM, 1/6W 180K OHM J
R475	24011391	CHIP, METAL FILM, 1/20W 390 OHM J
R476	24366823	CARBON FILM, 1/6W 82K OHM J
R477	24011273	CHIP, METAL FILM, 1/20W 27K OHM J
R478	24327133	METAL FILM, 1/4W 13K OHM F
R481	24011333	CHIP, METAL FILM, 1/20W 33K OHM J
R482	24327472	METAL FILM, 1/4W 4R7K F
R485	24338568	OXIDE METAL FILM, 1W 0.56 OHM J
R486	24552820	OXIDE METAL FILM, 1/2W 82 OHM J
R487	24552301	OXIDE METAL FILM, 1/2W 300 OHM J
R488	24327183	METAL FILM, 1/4W 18K OHM F
R489	24327183	METAL FILM, 1/4W 18K OHM F
R490	24011102	CHIP, METAL FILM, 1/20W 1K OHM J
R493	24366102	CARBON FILM, 1/6W 1K OHM J
R494	24366471	CARBON FILM, 1/6W 470 OHM J
R495	24366561	CARBON FILM, 1/6W 560 OHM J
R501	24011153	CHIP, METAL FILM, 1/20W 15K OHM J
R502	24366101	CARBON FILM, 1/6W 100 OHM J
R503	24366101	CARBON FILM, 1/6W 100 OHM J
R511	24366391	CARBON FILM, 1/6W 390 OHM J
R512	24011391	CHIP, METAL FILM, 1/20W 390 OHM J
R612	24011103	CHIP, METAL FILM, 1/20W 10K OHM J
R613	24011222	CHIP, METAL FILM, 1/20W 2.2K OHM J
R614	24366102	CARBON FILM, 1/6W 1K OHM J
R663	24011103	CHIP, METAL FILM, 1/20W 10K OHM J
R664	24011103	CHIP, METAL FILM, 1/20W 10K OHM J
R667	24011223	CHIP, METAL FILM, 1/20W 22K OHM J
R668	24366103	CARBON FILM, 1/6W 10K OHM J
R669	24011103	CHIP, METAL FILM, 1/20W 10K OHM J
R674	24011153	CHIP, METAL FILM, 1/20W 15K OHM J
R676	24366229	CARBON FILM, 1/6W 2.2 OHM J
R677	24366229	CARBON FILM, 1/6W 2.2 OHM J
R678	24011153	CHIP, METAL FILM, 1/20W 15K OHM J
R808	24019474	THERMISTOR, PTC THERMISTOR AC125V 1R5 M
R810	24568828	CERAMIC COVERED, 7W 0.82 OHM K
R814	24366182	CARBON FILM, 1/6W 1.8K OHM J
R818	24510150	CERAMIC COVERED, 5W 15 OHM J
R820	24322208	OXIDE METAL FILM, 1W 0.2 OHM J
R821	24321109	OXIDE METAL FILM, 1/2W 1 OHM J
R822	24366152	CARBON FILM, 1/6W 1.5K OHM J
R823	24366182	CARBON FILM, 1/6W 1.8K OHM J
R829	24004945	METAL FILM, 1W 0.18 OHM J
R831	24011103	CHIP, METAL FILM, 1/20W 10K OHM J
R835	24552681	OXIDE METAL FILM, 1/2W 680 OHM J
R861	24366104	CARBON FILM, 1/6W 100K OHM J
R862	24366104	CARBON FILM, 1/6W 100K OHM J
△ R898	24010001	CARBON FILM, 1/2W 3.9M OHM J
R901	24552102	OXIDE METAL FILM, 1/2W 1K OHM J
R902	24552102	OXIDE METAL FILM, 1/2W 1K OHM J
R903	24552102	OXIDE METAL FILM, 1/2W 1K OHM J
R904	24366103	CARBON FILM, 1/6W 10K OHM J

Location No.	Parts No.	Description
R905	24366101	CARBON FILM, 1/6W 100 OHM J
R914	24366561	CARBON FILM, 1/6W 560 OHM J
R915	24366301	CARBON FILM, 1/6W 300 OHM J
R916	24366820	CARBON FILM, 1/6W 82 OHM J
R917	24366102	CARBON FILM, 1/6W 1K OHM J
R918	24366102	CARBON FILM, 1/6W 1K OHM J
R920	24000880	FUSIBLE, 1W 5.1 OHM J
R921	24366561	CARBON FILM, 1/6W 560 OHM J
R922	24366301	CARBON FILM, 1/6W 300 OHM J
R924	24366820	CARBON FILM, 1/6W 82 OHM J
R927	24366102	CARBON FILM, 1/6W 1K OHM J
R928	24366561	CARBON FILM, 1/6W 560 OHM J
R929	24366301	CARBON FILM, 1/6W 300 OHM J
R930	24366820	CARBON FILM, 1/6W 82 OHM J
R932	24366272	CARBON FILM, 1/6W 2.7K OHM J
R934	24366271	CARBON FILM, 1/6W 270 OHM J
R935	24366102	CARBON FILM, 1/6W 1K OHM J
R936	24366750	CARBON FILM, 1/6W 75 OHM J
R942	24366562	CARBON FILM, 1/6W 5.6K OHM J
R943	24366562	CARBON FILM, 1/6W 5.6K OHM J
R944	24366562	CARBON FILM, 1/6W 5.6K OHM J
R960	24383153	OXIDE METAL FILM, 2W 15K OHM J
R961	24383153	OXIDE METAL FILM, 2W 15K OHM J
R962	24383153	OXIDE METAL FILM, 2W 15K OHM J
R968	24366150	CARBON FILM, 1/6W 15 OHM J
R977	24366122	CARBON FILM, 1/6W 1.2K OHM J
RA03	24366102	CARBON FILM, 1/6W 1K OHM J
RA04	24011102	CHIP, METAL FILM, 1/20W 1K OHM J
RA06	24011102	CHIP, METAL FILM, 1/20W 1K OHM J
RA07	24011102	CHIP, METAL FILM, 1/20W 1K OHM J
RA08	24366102	CARBON FILM, 1/6W 1K OHM J
RA09	24366102	CARBON FILM, 1/6W 1K OHM J
RA10	24366102	CARBON FILM, 1/6W 1K OHM J
RA15	24366102	CARBON FILM, 1/6W 1K OHM J
RA16	24366102	CARBON FILM, 1/6W 1K OHM J
RA17	24366102	CARBON FILM, 1/6W 1K OHM J
RA18	24366102	CARBON FILM, 1/6W 1K OHM J
RA21	24366472	CARBON FILM, 1/6W 4.7K OHM J
RA22	24011331	CHIP, METAL FILM, 1/20W 330 OHM J
RA23	24011331	CHIP, METAL FILM, 1/20W 330 OHM J
RA24	24011331	CHIP, METAL FILM, 1/20W 330 OHM J
RA25	24011331	CHIP, METAL FILM, 1/20W 330 OHM J
RA26	24366102	CARBON FILM, 1/6W 1K OHM J
RA27	24366102	CARBON FILM, 1/6W 1K OHM J
RA33	24011102	CHIP, METAL FILM, 1/20W 1K OHM J
RA35	24366102	CARBON FILM, 1/6W 1K OHM J
RA36	24011102	CHIP, METAL FILM, 1/20W 1K OHM J
RA37	24011331	CHIP, METAL FILM, 1/20W 330 OHM J
RA38	24011331	CHIP, METAL FILM, 1/20W 330 OHM J
RA40	24011101	CHIP, METAL FILM, 1/20W 100 OHM J
RA41	24011101	CHIP, METAL FILM, 1/20W 100 OHM J
RA61	24011103	CHIP, METAL FILM, 1/20W 10K OHM J
RA62	24366103	CARBON FILM, 1/6W 10K OHM J
RA67	24011472	CHIP, METAL FILM, 1/20W 4.7K OHM J
RA68	24011472	CHIP, METAL FILM, 1/20W 4.7K OHM J
RA71	24011683	CHIP, METAL FILM, 1/20W 68K OHM J
RA72	24011223	CHIP, METAL FILM, 1/20W 22K OHM J
RA73	24366103	CARBON FILM, 1/6W 10K OHM J
RA74	24366333	CARBON FILM, 1/6W 33K OHM J
RB01	24366271	CARBON FILM, 1/6W 270 OHM J
RB03	24366101	CARBON FILM, 1/6W 100 OHM J
RB09	24327470	METAL FILM, 1/4W 47 OHM F
RB11	24011103	CHIP, METAL FILM, 1/20W 10K OHM J
RB24	24366472	CARBON FILM, 1/6W 4.7K OHM J
RB25	24011472	CHIP, METAL FILM, 1/20W 4.7K OHM J

Location No.	Parts No.	Description
RB40	24011103	CHIP, METAL FILM, 1/20W 10K OHM J
RB42	24366102	CARBON FILM, 1/6W 1K OHM J
RB43	24011103	CHIP, METAL FILM, 1/20W 10K OHM J
RB44	24011103	CHIP, METAL FILM, 1/20W 10K OHM J
RB45	24366181	CARBON FILM, 1/6W 180 OHM J
RB46	24011101	CHIP, METAL FILM, 1/20W 100 OHM J
RB47	24011332	CHIP, METAL FILM, 1/20W 3.3K OHM J
RB49	24011332	CHIP, METAL FILM, 1/20W 3.3K OHM J
RB60	24011101	CHIP, METAL FILM, 1/20W 100 OHM J
RB61	24011224	CHIP, METAL FILM, 1/20W 220K OHM J
RB62	24011123	CHIP, METAL FILM, 1/20W 12K OHM J
RB63	24011392	CHIP, METAL FILM, 1/20W 3.9K OHM J
RB64	24011103	CHIP, METAL FILM, 1/20W 10K OHM J
RB65	24366221	CARBON FILM, 1/6W 220 OHM J
RB66	24011103	CHIP, METAL FILM, 1/20W 10K OHM J
RB67	24011102	CHIP, METAL FILM, 1/20W 1K OHM J
RG05	24011102	CHIP, METAL FILM, 1/20W 1K OHM J
RG08	24011394	CHIP, METAL FILM, 1/20W 390K OHM J
RG09	24011473	CHIP, METAL FILM, 1/20W 47K OHM J
RG14	24011332	CHIP, METAL FILM, 1/20W 3.3K OHM J
RG15	24011152	CHIP, METAL FILM, 1/20W 1.5K OHM J
RG16	24327153	METAL FILM, 1/4W 15K OHM J
RG17	24011472	CHIP, METAL FILM, 1/20W 4.7K OHM J
RG22	24366101	CARBON FILM, 1/6W 100 OHM J
RG23	24366101	CARBON FILM, 1/6W 100 OHM J
RG43	24011472	CHIP, METAL FILM, 1/20W 4.7K OHM J
RG44	24011222	CHIP, METAL FILM, 1/20W 2.2K OHM J
RI01	24011270	CHIP, METAL FILM, 1/20W 27 OHM J
RI02	24011512	CHIP, METAL FILM, 1/20W 5.1K OHM J
RI03	24011102	CHIP, METAL FILM, 1/20W 1K OHM J
RI04	24011470	CHIP, METAL FILM, 1/20W 47 OHM J
RI05	24011361	CHIP, METAL FILM, 1/20W 360 OHM J
RI06	24011519	METAL FILM CHIP, 1/16W 5.1 J
RI07	24011360	METAL FILM CHIP, 1/20W 36 J
RI08	24011332	CHIP, METAL FILM, 1/20W 3.3K OHM J
RI09	24011123	CHIP, METAL FILM, 1/20W 12K OHM J
RI11	24011113	CHIP, METAL FILM, 1/20W 11K OHM J
RI13	24011112	CHIP, METAL FILM, 1/20W 1.1K OHM J
RI14	24011102	CHIP, METAL FILM, 1/20W 1K OHM J
RI15	24011182	CHIP, METAL FILM, 1/20W 1.8K OHM J
RI16	24011122	CHIP, METAL FILM, 1/20W 1.2K OHM J
RI17	24011101	CHIP, METAL FILM, 1/20W 100 OHM J
RI18	24011132	CHIP, METAL FILM, 1/20W 1.3K OHM J
RI19	24011391	CHIP, METAL FILM, 1/20W 390 OHM J
RI20	24011821	CHIP, METAL FILM, 1/20W 820 OHM J
RI21	24011271	CHIP, METAL FILM, 1/20W 270 OHM J
RI22	24011475	METAL FILM CHIP, 1/16W 4R7M K
RI23	24011221	CHIP, METAL FILM, 1/20W 220 OHM J
RI27	24011103	CHIP, METAL FILM, 1/20W 10K OHM J
RI28	24011123	CHIP, METAL FILM, 1/20W 12K OHM J
RI30	24011102	CHIP, METAL FILM, 1/20W 1K OHM J
RI32	24366750	CARBON FILM, 1/6W 75 OHM J
RI33	24011124	CHIP, METAL FILM, 1/20W 120K OHM J
RI35	24011563	CHIP, METAL FILM, 1/20W 56K OHM J
RI36	24011683	CHIP, METAL FILM, 1/20W 68K OHM J
RI51	24066046	VARIABLE. CARBON, 0.1W 20K N
RI52	24011101	CHIP, METAL FILM, 1/20W 100 OHM J
RJ41	24000445	CHIP JUMPER, 1608TYPE
RJ42	24000445	CHIP JUMPER, 1608TYPE
RJ43	24000445	CHIP JUMPER, 1608TYPE
RJ44	24000445	CHIP JUMPER, 1608TYPE
RJ45	24000445	CHIP JUMPER, 1608TYPE
RJ46	24000445	CHIP JUMPER, 1608TYPE
RJ47	24000445	CHIP JUMPER, 1608TYPE
RR07	24011102	CHIP, METAL FILM, 1/20W 1K OHM J

Location No.	Parts No.	Description
RR93	24011472	CHIP, METAL FILM, 1/20W 4.7K OHM J
RS02	24011682	CHIP, METAL FILM, 1/20W 6.8K OHM J
RS04	24011682	CHIP, METAL FILM, 1/20W 6.8K OHM J
RS08	24011682	CHIP, METAL FILM, 1/20W 6.8K OHM J
RS10	24011682	CHIP, METAL FILM, 1/20W 6.8K OHM J
RS25	24011682	CHIP, METAL FILM, 1/20W 6.8K OHM J
RS26	24011682	CHIP, METAL FILM, 1/20W 6.8K OHM J
RS28	24366472	CARBON FILM, 1/6W 4.7K OHM J
RS40	24366101	CARBON FILM, 1/6W 100 OHM J
RS41	24011152	CHIP, METAL FILM, 1/20W 1.5K OHM J
RS42	24366101	CARBON FILM, 1/6W 100 OHM J
RS60	24011101	CHIP, METAL FILM, 1/20W 100 OHM J
RS61	24011222	CHIP, METAL FILM, 1/20W 2.2K OHM J
RS62	24011101	CHIP, METAL FILM, 1/20W 100 OHM J
RS63	24011222	CHIP, METAL FILM, 1/20W 2.2K OHM J
RS64	24011102	CHIP, METAL FILM, 1/20W 1K OHM J
RS65	24011102	CHIP, METAL FILM, 1/20W 1K OHM J
RS66	24011102	CHIP, METAL FILM, 1/20W 1K OHM J
RS68	24011223	CHIP, METAL FILM, 1/20W 22K OHM J
RS69	24011223	CHIP, METAL FILM, 1/20W 22K OHM J
RS70	24011104	CHIP, METAL FILM, 1/20W 100K OHM J
RS71	24011104	CHIP, METAL FILM, 1/20W 100K OHM J
RV01	24011750	CHIP, METAL FILM, 1/20W 75 OHM J
RV02	24011750	CHIP, METAL FILM, 1/20W 75 OHM J
RV03	24011750	CHIP, METAL FILM, 1/20W 75 OHM J
RV04	24011750	CHIP, METAL FILM, 1/20W 75 OHM J
RV05	24366750	CARBON FILM, 1/6W 75 OHM J
RV07	24366103	CARBON FILM, 1/6W 10K OHM J
RV08	24366102	CARBON FILM, 1/6W 1K OHM J
RV09	24366103	CARBON FILM, 1/6W 10K OHM J
RV10	24000445	CHIP JUMPER, 1608TYPE
RV12	24366101	CARBON FILM, 1/6W 100 OHM J
RV14	24011102	CHIP, METAL FILM, 1/20W 1K OHM J
RV15	24366102	CARBON FILM, 1/6W 1K OHM J
RV16	24366471	CARBON FILM, 1/6W 470 OHM J
RV19	24011101	CHIP, METAL FILM, 1/20W 100 OHM J
RV20	24011101	CHIP, METAL FILM, 1/20W 100 OHM J
RV60	24552101	OXIDE METAL FILM, 1/2W 100 OHM J
RV61	24011101	CHIP, METAL FILM, 1/20W 100 OHM J
RV62	24366750	CARBON FILM, 1/6W 75 OHM J
RV63	24366221	CARBON FILM, 1/6W 220 OHM J
RW02	24011750	CHIP, METAL FILM, 1/20W 75 OHM J
RW03	24011750	CHIP, METAL FILM, 1/20W 75 OHM J
RZ05	24366101	CARBON FILM, 1/6W 100 OHM J
RZ06	24366101	CARBON FILM, 1/6W 100 OHM J
RZ07	24366221	CARBON FILM, 1/6W 220 OHM J
RZ08	24011151	CHIP, METAL FILM, 1/20W 150 OHM J
RZ10	24011102	CHIP, METAL FILM, 1/20W 1K OHM J
RZ11	24011102	CHIP, METAL FILM, 1/20W 1K OHM J
RZ12	24011182	CHIP, METAL FILM, 1/20W 1.8K OHM J
RZ13	24011392	CHIP, METAL FILM, 1/20W 3.9K OHM J
RZ14	24011123	CHIP, METAL FILM, 1/20W 12K OHM J
RZ15	24011151	CHIP, METAL FILM, 1/20W 150 OHM J
RZ16	24366101	CARBON FILM, 1/6W 100 OHM J
RZ17	24366181	CARBON FILM, 1/6W 180 OHM J
RZ18	24011121	CHIP, METAL FILM, 1/20W 120 OHM J
RZ21	24011471	CHIP, METAL FILM, 1/20W 470 OHM J
RZ22	24011101	CHIP, METAL FILM, 1/20W 100 OHM J
RZ28	24011102	CHIP, METAL FILM, 1/20W 1K OHM J
RZ34	24011474	CHIP, METAL FILM, 1/20W 470K OHM J
RZ35	24011821	CHIP, METAL FILM, 1/20W 820 OHM J
RZ36	24011123	CHIP, METAL FILM, 1/20W 12K OHM J
RZ43	24011220	CHIP, METAL FILM, 1/20W 22 OHM J
RZ44	24011102	CHIP, METAL FILM, 1/20W 1K OHM J
RZ45	24366220	CARBON FILM, 1/6W 22 OHM J

Location No.	Parts No.	Description
RZ46	24011102	CHIP, METAL FILM, 1/20W 1K OHM J
RZ49	24011102	CHIP, METAL FILM, 1/20W 1K OHM J
RZ60	24366102	CARBON FILM, 1/6W 1K OHM J
RZ61	24011822	CHIP, METAL FILM, 1/20W 8.2K OHM J
RZ62	24011103	CHIP, METAL FILM, 1/20W 10K OHM J
RZ63	24011103	CHIP, METAL FILM, 1/20W 10K OHM J
RZ65	24011102	CHIP, METAL FILM, 1/20W 1K OHM J
RZ66	24011102	CHIP, METAL FILM, 1/20W 1K OHM J
RZ68	24011102	CHIP, METAL FILM, 1/20W 1K OHM J
RZ71	24011103	CHIP, METAL FILM, 1/20W 10K OHM J
COILS & TRANSFORMERS		
L101	23289846	COIL, PEAKING, TRF4101AT
L201	23238703	COIL, PEAKING, TRF4820AJ
L301	23103145	FERRITE CHOKE, TEM2011AA
L302	23103145	FERRITE CHOKE, TEM2011AA
L303	23103248	FERRITR CHOKE, TEM2014AA
L401	23280016	COIL, PEAKING, TRF4100AZ
L441	23233092	COIL, TLN2138G
L442	23248121	COIL, CHOKE, TLN3383D
L461	23248173	COIL, CHOKE, TLN3333AD
L501	23238711	COIL, PEAKING, TRF4180AJ
L502	23289844	COIL, PEAKING, TRF4470AT
L805	23248213	COIL, CHOKE, TLN3481AH
L806	23248213	COIL, CHOKE, TLN3481AH
L815	23103145	FERRITE CHOKE, TEM2011AA
L824	23103145	FERRITE CHOKE, TEM2011AA
L883	23103145	FERRITE CHOKE, TEM2011AA
L885	23248073	COIL, CHOKE, TLN3299D
L886	23103145	FERRITE CHOKE, TEM2011AA
△ L901	23200481	COIL, DG 0.71CU 40T-2LOOP, TSB-2415AH
L902	23280024	COIL, PEAKING, TRF4221AZ
L903	23280024	COIL, PEAKING, TRF4221AZ
L904	23280024	COIL, PEAKING, TRF4221AZ
LA01	23289840	COIL, PEAKING, TRF4100AT
LG01	23289220	COIL, PEAKING, TRF4220AF
LI01	23246051	COIL, CHIP-INDUCTOR-0.22MMH K, COLTRF4R22CE
LI02	23246104	CHIP INDUCTOR, TRFR5C
LI51	23289470	COIL, PEAKING, TRF4470AF
LI52	23289120	COIL, PEAKING, TRF4120AF
LI53	23289180	COIL, PEAKING, TRF4180AF
LI54	23232050	COIL, VARIABLE, TRF3554D
LI55	23289129	COIL, PEAKING 1.0MMH J 0405, TRF41R2AF
LI56	23289180	COIL, PEAKING, TRF4180AF
LI57	23289228	COIL, PEAKING, TRF4R22AF
LV01	23289840	COIL, PEAKING, TRF4100AT
LV02	23103159	FILTER, EMI, TEM2028AA, 7.5X6.4X8 60MMH 0.5A
LV98	23103159	FILTER, EMI, TEM2028AA, 7.5X6.4X8 60MMH 0.5A
LV99	23103159	FILTER, EMI, TEM2028AA, 7.5X6.4X8 60MMH 0.5A
LZ01	23289840	COIL, PEAKING, TRF4100AT
LZ02	23103145	FERRITE CHOKE, TEM2011AA
LZ03	23103145	FERRITE CHOKE, TEM2011AA
LZ10	23238707	COIL, PEAKING, TRF4390AJ
LZ20	23238718	COIL, PEAKING, TRF4479AJ
LZ21	23238711	COIL, PEAKING, TRF4180AJ
LZ22	23238506	COIL, PEAKING, TRF4229AJ
T401	23224367	TRANSFORMER, HORIZ DRIVER, TLN1098AH
△ T461	23236733	TRANSFORMER, FLYBACK, TFB4192AS
△ T801	23211739	COIL, LINE FILTER, TRF3229AL
△ T840	23217572	TRANSFORMER, POWER EI28 11.5V, TPW1571AT

Location No.	Parts No.	Description
T862	23217583	TRANSFORMER, CONV TRS EER40, TPW3498AB
SEMICONDUCTORS		
Q203	23314965	TRANSISTOR, KTC3198 Y
Q204	23114460	TRANSISTOR, RN1204
Q205	23114460	TRANSISTOR, RN1204
Q301	23319787	IC, LA7833S
Q301B	72471082	SCREW, 3X10MM
Q370	23314962	TRANSISTOR, KTA1266 Y
Q402	23114755	TRANSISTOR, 2SC2482FA-1
Q403	23314444	TRANSISTOR, 2SC4721, P
Q404	23314955	TRANSISTOR, 2SD2553(FA)
Q404B	72471082	SCREW, 3X10MM
Q421	23009187	IC, REGULATOR +9V 4%, KIA7809API
Q421B	23035308	SCREW, 3X8MM, TAPPING
Q460	23314938	TRANSISTOR, 2SD2493(P)
Q460B	72471082	SCREW, 3X10MM
Q461	23314962	TRANSISTOR, KTA1266 Y
Q471	23314961	TRANSISTOR, KTA1266 O
Q472	23314965	TRANSISTOR, KTC3198 Y
Q480	23114759	TRANSISTOR, 2SA949-Y
Q481	23314965	TRANSISTOR, KTC3198 Y
Q482	23314965	TRANSISTOR, KTC3198 Y
Q483	23114469	TRANSISTOR, RN2201
Q501	23906843	IC, TA1310N
Q610	23000249	IC, TA8265K
Q610B	70391356	SCREW, BITTB3X10 SZN
Q611	23114623	TRANSISTOR, 2SC2878-A(TEM)
Q612	23314962	TRANSISTOR, KTA1266 Y
Q613	23114623	TRANSISTOR, 2SC2878-A(TEM)
Q801	23135032	IC, STR-G5624A
Q801B	72471082	SCREW, 3X10MM
Q805	23114459	TRANSISTOR, RN1205
Q830	23009188	IC, KIA7805API
Q830B	23035308	SCREW, 3X8MM, TAPPING
Q831	23314965	TRANSISTOR, KTC3198 Y
Q840	23000140	IC, MM1437AS
Q843	23114459	TRANSISTOR, RN1205
Q901	23314780	TRANSISTOR, 2SC4544
Q902	23314965	TRANSISTOR, KTC3198 Y
Q903	23314780	TRANSISTOR, 2SC4544
Q904	23314965	TRANSISTOR, KTC3198 Y
Q905	23314780	TRANSISTOR, 2SC4544
Q906	23314965	TRANSISTOR, KTC3198 Y
Q907	23314962	TRANSISTOR, KTA1266 Y
Q908	23314965	TRANSISTOR, KTC3198 Y
QA01	23009196	IC, TMP88CP38AN-3PV2
QA02	23009326	IC, AT24C04-10PI-
QB01	23314965	TRANSISTOR, KTC3198 Y
QB03	23114459	TRANSISTOR, RN1205
QB23	23314965	TRANSISTOR, KTC3198 Y
QB40	23314965	TRANSISTOR, KTC3198 Y
QB41	23314965	TRANSISTOR, KTC3198 Y
QB60	23314962	TRANSISTOR, KTA1266 Y
QB61	23314965	TRANSISTOR, KTC3198 Y
QB62	23314965	TRANSISTOR, KTC3198 Y
QG01	23906499	IC, UPC1851BCU
QI01	23114611	TRANSISTOR, 2SC3357
QI02	23314994	TRANSISTOR, 2SA1576A106
QI03	23314993	TRANSISTOR, 2SC4081 Q
QI05	23009240	IC, VIF/SIF SSOP24PIN, TA1274F(FA03A5,EL)
QS60	23314965	TRANSISTOR, KTC3198 Y
QS61	23314965	TRANSISTOR, KTC3198 Y
QS62	23114466	TRANSISTOR, RN2204

Location No.	Parts No.	Description
QS63	23114623	TRANSISTOR, 2SC2878-A(TEM
QS64	23114623	TRANSISTOR, 2SC2878-A(TEM
QV01	23000686	IC, MM1311BD
QV02	23314965	TRANSISTOR, KTC3198 Y
QV60	23314965	TRANSISTOR, KTC3198 Y
QZ01	23009176	IC, 3LINE-DIGITAL Y/C SEPA, TC90A53N
QZ04	23314965	TRANSISTOR, KTC3198 Y
QZ05	23314962	TRANSISTOR, KTA1266 Y
QZ06	23314965	TRANSISTOR, KTC3198 Y
QZ08	23314962	TRANSISTOR, KTA1266 Y
QZ14	23314962	TRANSISTOR, KTA1266 Y
QZ20	23314965	TRANSISTOR, KTC3198 Y
QZ21	23314962	TRANSISTOR, KTA1266 Y
QZ23	23314962	TRANSISTOR, KTA1266 Y
D101	23316755	DIODE, ZENER, MTZJ33C
D201	23118859	DIODE, 1SS133
D221	23118859	DIODE, 1SS133
D222	23118859	DIODE, 1SS133
D225	23357281	DIODE, DZ9.1 BS A
D226	23357281	DIODE, DZ9.1 BS A
D301	23357366	DIODE, FR105-B5
D302	23357366	DIODE, FR105-B5
D310	23118859	DIODE, 1SS133
D313	23118859	DIODE, 1SS133
D370	23357267	DIODE, DZ5.6 BS B
D371	23118859	DIODE, 1SS133
D406	23357366	DIODE, FR105-B5
D408	23316414	DIODE, 3JH41 (FALC3)
D409	23118622	DIODE, ZENER, RD10ES B2
D411	23357279	DIODE, DZ8.2 BS B
D430	23357283	DIODE, DZ9.1 BS C
D441	23357282	DIODE, DZ9.1 BS B
D444	23316254	DIODE, ERC06-15
D461	23118338	DIODE, RU4AM LF-K2
D462	23118859	DIODE, 1SS133
D466	23357248	DIODE, DZ2.7 BS B
D467	23357366	DIODE, FR105-B5
D471	23357366	DIODE, FR105-B5
D472	23115774	DIODE, ZENER, RD6.2E(FA-1)
D473	23118859	DIODE, 1SS133
D480	23357299	DIODE, DZ16 BS A
D611	23118859	DIODE, 1SS133
D612	23118859	DIODE, 1SS133
D801	23316391	DIODE, D3SB60(4103)
D805	23118859	DIODE, 1SS133
D806	23357366	DIODE, FR105-B5
D807	23118859	DIODE, 1SS133
D810	23316269	DIODE, AK04
D830	23118859	DIODE, 1SS133
D840	23316962	DIODE, S1WBA20
D841	23357267	DIODE, DZ5.6 BS B
D845	23118859	DIODE, 1SS133
D846	23118859	DIODE, 1SS133
D883	23357344	DIODE, RU3AM
D885	23118094	DIODE, EU2A
△ D899	24019485	VARISTOR, TNR10V431K
D901	23118859	DIODE, 1SS133
D902	23118859	DIODE, 1SS133
D904	23118859	DIODE, 1SS133
D905	23118859	DIODE, 1SS133
D906	23118859	DIODE, 1SS133
D911	23118095	DIODE, ERB44-06
DA42	23357267	DIODE, DZ5.6 BS B
DB03	23358522	DIODE, LED, SIR-56SB3F
DB45	23118859	DIODE, 1SS133

Location No.	Parts No.	Description
DE50	23358571	DIODE, LED, BT-H254N-31-SH
DV01	23357281	DIODE, DZ9.1 BS A
DV03	23357281	DIODE, DZ9.1 BS A
DV05	23357281	DIODE, DZ9.1 BS A
DV09	23357281	DIODE, DZ9.1 BS A
DV27	23357281	DIODE, DZ9.1 BS A
MISCELLANEOUS		
B205	23974994	BAND, KESSOKU
B230	23037312	SCREW, BTBW3X12SZN
B231	23035412	SCREW, BTB4X12SZN
B232	23035312	SCREW, BTB3X12SZN
△ F470	23144906	FUSE, CARTRIDGE, F1.25U1
F470A	23165433	FUSE HOLDER, 5.2 SOC
△ F801	23144518	FUSE, CARTRIDGE, 125V 10A
F801A	23165433	FUSE HOLDER, 5.2 SOC
△ F802	23144893	FUSE, 3.15A
F802A	23165433	FUSE HOLDER, 5.2 SOC
△ F803	23144897	FUSE, 2A 125V
F803A	23165433	FUSE HOLDER, 5.2 SOC
G217	24366153	CARBON FILM, 1/6W 15K OHM J
G402	23103145	FERRITE CHOKE, TEM2011AA
G403	23103145	FERRITE CHOKE, TEM2011AA
G404	23238714	COIL, PEAKING, TRF4100AJ
G500	23280016	COIL, PEAKING, TRF4100AZ
G816	23103145	FERRITE CHOKE, TEM2011AA
G890	23280016	COIL, PEAKING, TRF4100AZ
G891	23280016	COIL, PEAKING, TRF4100AZ
G908	23280016	COIL, PEAKING, TRF4100AZ
G933	24366750	CARBON FILM, 1/6W 75 OHM J
GJ01	24000445	CHIP JUMPER, 1608TYPE
GJ02	24000445	CHIP JUMPER, 1608TYPE
GR01	24366470	CARBON FILM, 1/6W 47 OHM J
GR02	24011101	CHIP, METAL FILM, 1/20W 100 OHM J
GR03	24011101	CHIP, METAL FILM, 1/20W 100 OHM J
KB01	23906805	IC, REMOTE PHOTO RECIEVER, PIC-TB17
△ M461A	23192957	ANODE CAP ASSY, TCC5602AT
△ M461B	23504203	CABLE, FOCUS
M461C	23504204	CABLE, SCREEN
N726	23969041	TAPE WHITE 3M #1, W=1 INCH TNP COMMON
△ P801	23372115	POWER CORD, U/C 125V10A HSV 4, CMC-02P 3
△ P910	23164725	CONNECTOR, PLUG 2P
PV01	23365575	JACK, Y/C JLC, YKF51-5575
PV02	23365990	JACK, PIN 6P INCHAN, JACK 6P
PV03	23365991	CONNECTOR, JACK
PV04	23365763	PHONO JACK, 3P
SA01	23344443	SWITCH, TACTING SWITCH TSV TYP TSVB-1
SA02	23344443	SWITCH, TACTING SWITCH TSV TYP TSVB-1
SA03	23344443	SWITCH, TACTING SWITCH TSV TYP TSVB-1
SA04	23344443	SWITCH, TACTING SWITCH TSV TYP TSVB-1
SA05	23344443	SWITCH, TACTING SWITCH TSV TYP TSVB-1
SA06	23344443	SWITCH, TACTING SWITCH TSV TYP TSVB-1
SA07	23344443	SWITCH, TACTING SWITCH TSV TYP TSVB-1
△ SR81	23146564	RELAY, DC12V, TV5, DG-3
△ SR83	23146564	RELAY, DC12V, TV5, DG-3
△ V901A	23902068	SOCKET CRT, 10P HOSIDEN, HPS0360
W661	23351191	SPEAKER, 60X120 8-OHM 5W, SPK-1360AE
W662	23351191	SPEAKER, 60X120 8-OHM 5W , SPK-1360AE
X401	23153721	CERAMIC RESONATOR, 503KHZ
X501	23153961	CRYSTAL, 3.58MHZ
XA01	23153504	CERAMIC RESONATOR, 8.00MHZ 25OHM
ZI51	23303197	PIF SAW FILTER, TSF1248P
ZI52	23303271	FILTER, TRAP 4.5MHZ, TCF1138AM

Location No.	Parts No.	Description
ZI53	23303289	FILTER, TCF1141AM
ZI55	23303244	FILTER, CERAMIC TRAP, TCF1121AM
PC BOARD ASSEMBLIES		
* U001	23788269	IF BOARD, PD1022A
* U901	23787662	CRT DRIVE BOARD, PD0629B
* U902	23788423	MAIN BOARD, PD1050B
* U903	23787663	F.AV BOARD, PD0715A
PICTURE TUBE		
△ V901	23312989	PICTURE TUBE, TDD36FSAK/2, A90AKB50X05(V)
TUNER		
H001	23321456	TUNER, US181CH IIC F 5V, ELA51LX7
ACCESSORIES		
K912	23306495	REMOCON HAND UNIT IR, CTVUSA, CT-90157
Y101	23565888	OWNER'S MANUAL, ENGLISH/ FRENCH, 36A43
CABINET PARTS		
△ A201	23540611	COVER, FRONT COVER ASSY 36A61 36A61
A213	23427939	DOOR, DOOR 36AX61 36AX61
A223	23445475	BUTTON, CONTROL BUTTON 36AX61 36AX60
A431	23540477	COVER, BACK COVER PROP 36AX61 36AX61
A701	23064520	CARTON, CARTON BOX 36A61 36A61
A703	23946145	PACKING, TOP PACKING 36AX61 36AX61
A708	23946146	PACKING, BOTTOM PACKING 36AX61 36AX61

Location No.	Parts No.	Description
--------------	-----------	-------------

**THIS PAGE IS
INTENTIONALLY LEFT
BLANK.**

MAIN BOARD PD1050B
BOTTOM (FOIL) SIDE

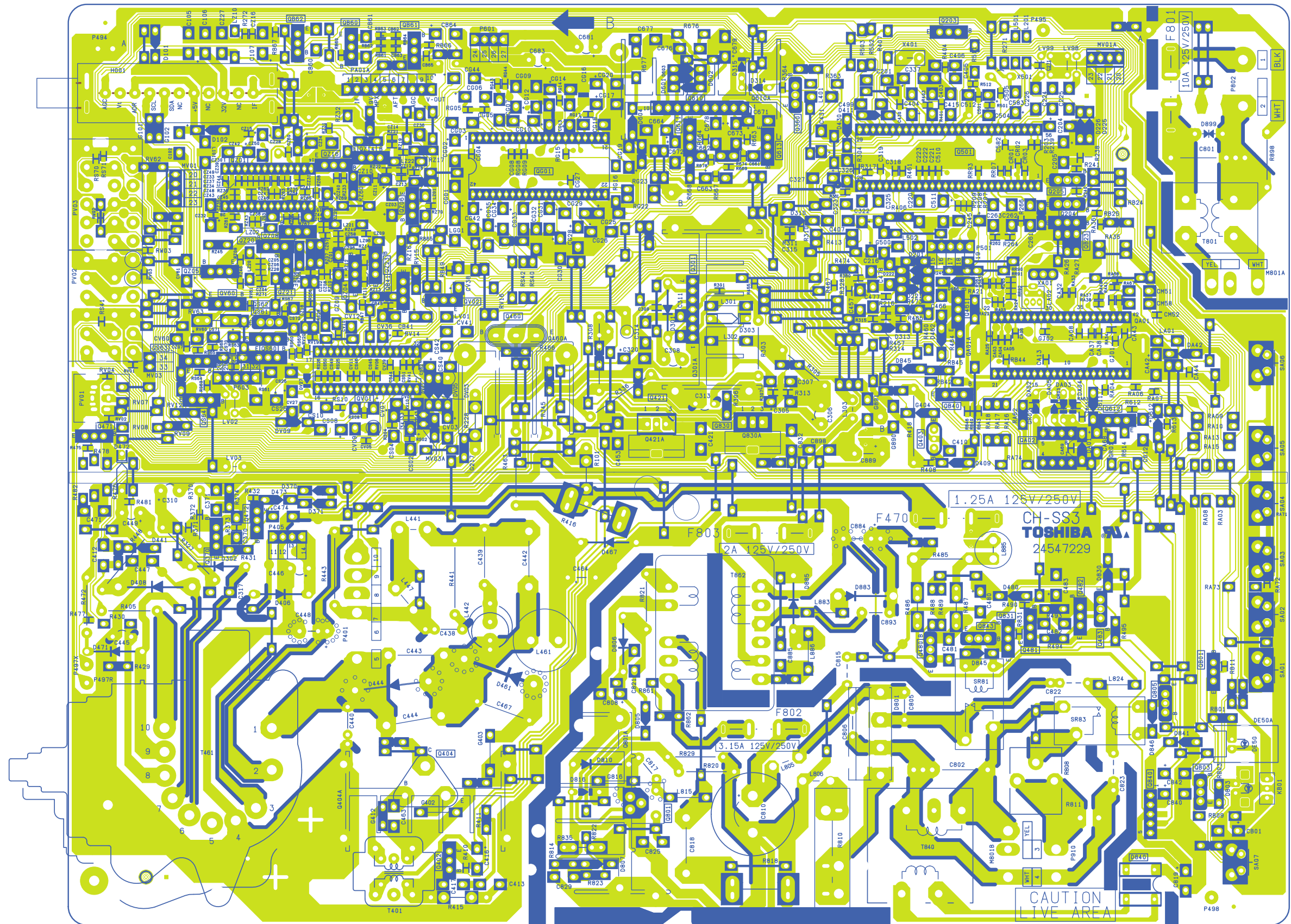

CRT DRIVE BOARD PD0629B
BOTTOM (FOIL) SIDE

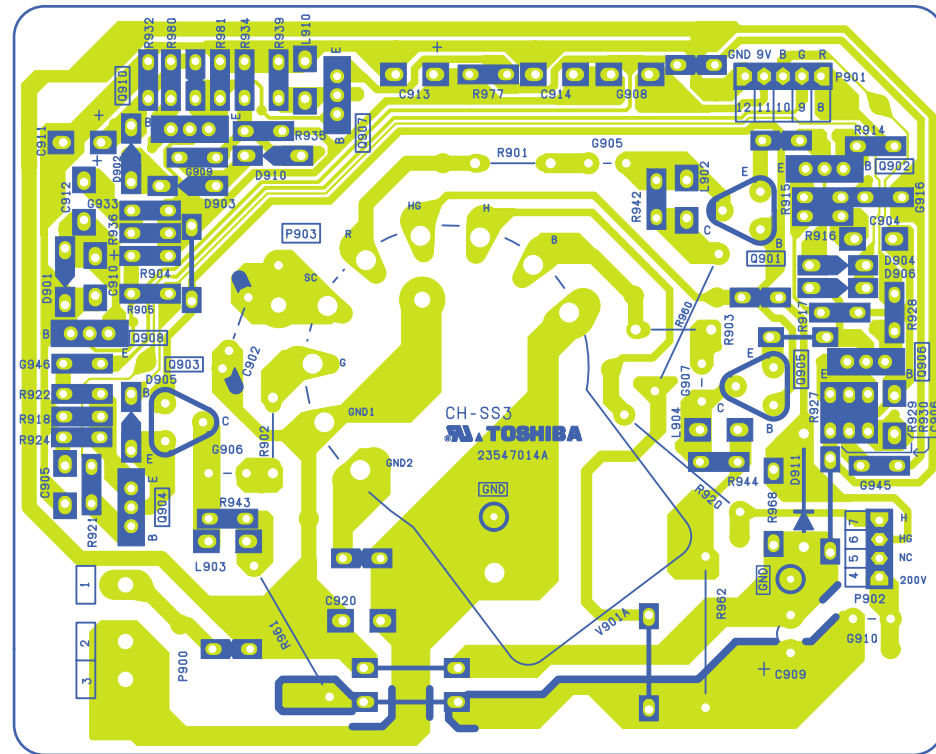

TERMINAL VIEW OF TRANSISTORS

- ① 2SD2253
(old)
2SC5243

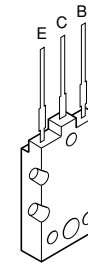

- ② 2SC3852
2SD1763A
2SC1569
2SC4544
2SA1788
2SA1306
2SA1186A

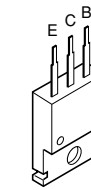

- ③ 2SC752GTM
2SC2482
2SC2655
2SC4721P



- ④ 2SC752
2SA562TM
2SA1015
2SC1815
2SC2878
2SC1740S
2SC2120
2SA9335



- ⑤ 2SA1788

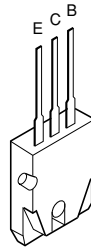

- ⑥ RN2203
RN2201
RN2004
RN1203
RN1204
RN2204
RN1205
RN1202
RN1201



- ⑦ 2SD1554
2SD2253
2SD1556
2SC5143
2SD2553

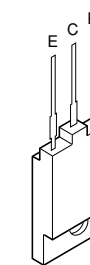

- ⑧ ON4409

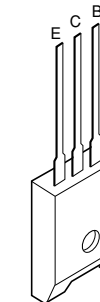

FRONT. AV BOARD PD0715A
BOTTOM (FOIL) SIDE

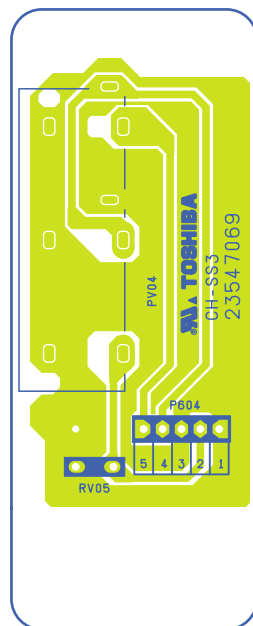

IF BOARD PD1022A
BOTTOM (FOIL) SIDE

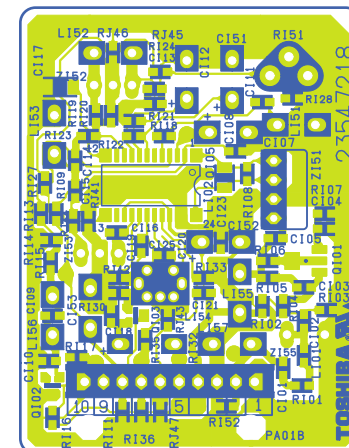

CIRCUIT BLOCK DIAGRAM

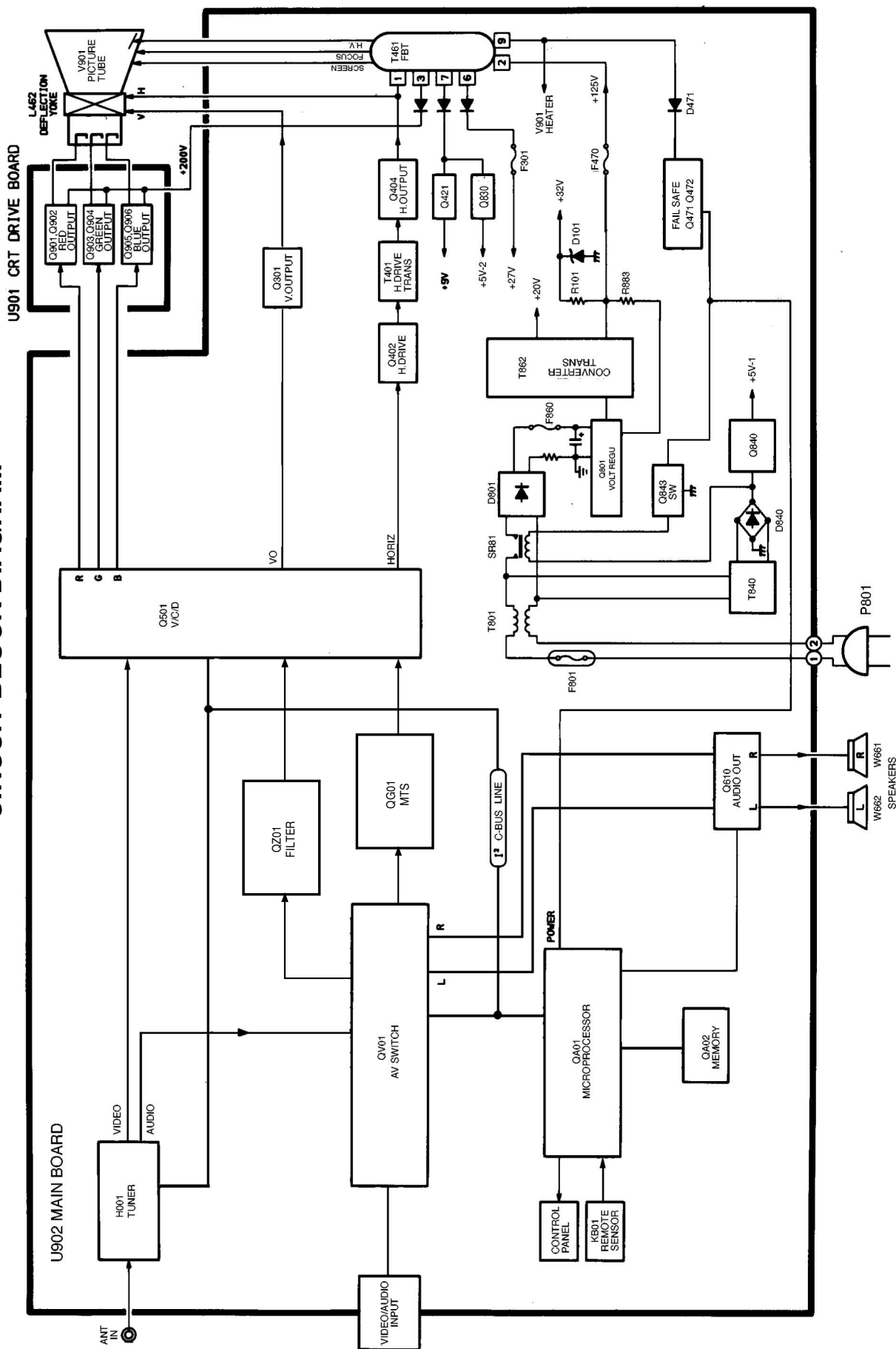

SPECIFICATIONS	
TELEVISION SYSTEM	NTSC standard
CHANNEL COVERAGE	VHF: 2 through 13 UHF: 14 through 69 Cable TV: mid band (A-8 through A-1, A through I) super band (J through W) hyper band (AA through ZZ, AAA, BBB) ultra band (65 through 94, 100 through 125)
POWER SOURCE	120V AC, 60Hz, 94W
AUDIO POWER	5W + 5W
SPEAKER TYPE	2-3/8 x 4-3/4 inches (60 x 120 mm)
VIDEO/AUDIO TERMINALS	S-VIDEO INPUT Y-INPUT: 1V (p-p), 75 ohm, negative sync. C-INPUT: 0.286V (p-p) (burst signal), 75 ohm VIDEO/AUDIO INPUT (VIDEO1/VIDEO2) VIDEO: 1V(p-p), 75 ohm, negative sync. AUDIO: 150mV(rms) (30% modulation equivalent, 47k ohm) ColorStream™ (component video) INPUT Y: 1V (p-p), 75 ohm C _R : 0.7V (p-p), 75 ohm C _B : 0.7V (p-p), 75 ohm VIDEO/AUDIO OUTPUT VIDEO: 1V(p-p), 75 ohm, negative sync. AUDIO: 150mV(rms) (30% modulation equivalent, 4.7k ohm)
DIMENSIONS	Width 970 mm Height 765.5 mm Depth 640 mm
MASS	69.9 kg (Approx.)

* Please refer to owner's manual in detail.

TOSHIBA CORPORATION
1-1, SHIBAURA 1-CHOME, MINATO-KU, TOKYO 105-8001, JAPAN