

18" EXTENDED LOW FREQUENCY LOUDSPEAKER

The Radian 2218 18" low frequency transducer produces extremely high levels of bass energy. This woofer is designed as an extended low frequency device, used as a subwoofer or general purpose LF transducer. Notably this transducer will perform very well in a 4.5 cubic foot enclosure.

Integral to this design is a composite ribbed cone, reinforced with Kevlar®. The voice coil is edge wound aluminum for better transient response, however our advanced adhesives give it the power handling capacity of more conventional copper voice coils. With 600 watts RMS power handling and a high-energy magnetic structure with a venturi cross section to increase ventilation efficiency, the output sensitivity is 96 dB (one watt, one meter) with a continuous sound pressure level of 123 dB.



- ✓ **LOW DISTORTION**
- ✓ **4" VOICE COIL**
- ✓ **KEVLAR® IMPREGNATED CONE**
- ✓ **VENTURI-VENTED COOLING**
- ✓ **600 WATTS RMS**
- ✓ **26 Hz LOW FREQUENCY CUTOFF**
- ✓ **CAST ALUMINUM FRAME**
- ✓ **HIGH SENSITIVITY**

18" EXTENDED LOW FREQUENCY LOUDSPEAKER

SPECIFICATIONS

FREQUENCY RESPONSE	26 Hz – 100 Hz
MAXIMUM POWER HANDLING*	600 watts RMS
SENSITIVITY**	95 dB
RECOMMENDED CROSSOVER	80 – 120 Hz
NOMINAL IMPEDANCE	8 ohms
VOICE COIL DIAMETER	4.0" (101.6mm)
RECOMMENDED ENCLOSURE	6 ft. ³ – 12 ft. ³ (170 – 340 liters)
WOOFER CONE MATERIAL	Kevlar® Reinforced Paper
VOICE COIL MATERIAL	Edgewood Aluminum
BASKET MATERIAL	Cast Aluminum
OVERALL DIAMETER	18.31" (465mm)
MOUNTING BOLT CIRCLE	17.38" (441.33mm)
CUT-OUT DIAMETER	16.88" (429mm)
OVERALL DEPTH	7.59" (192.78mm)
INPUT CONNECTORS	Pushbutton Terminals
WEIGHT	26 lbs. (11.8 kg)
THIELE/SMALL PARAMETERS:	
QTS	0.522
QMS	3.1591
QES	0.6254
VAS	10 (ft. ³), 286 (liters)
Fs (Hz)	33.8
XMAX (IN)	0.187
RE (Ω)	6.3
SD (IN ²)	201 (0.130M ²)

*EIA Standard RS-426A

**One watt at one meter (averaged 100 Hz – 800 Hz)

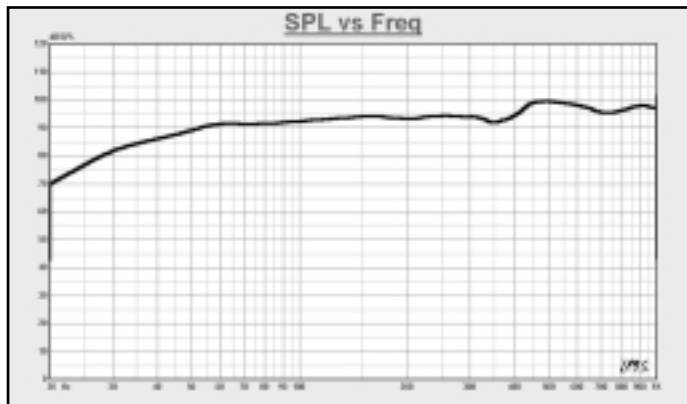

Amplitude vs. Frequency Response of the Radian 2218 as measured in a 5.6 cubic ft. enclosure, tuned to 36 Hz on axis with a one watt (2.83 Vrms), swept sine wave input at 8 ohms.

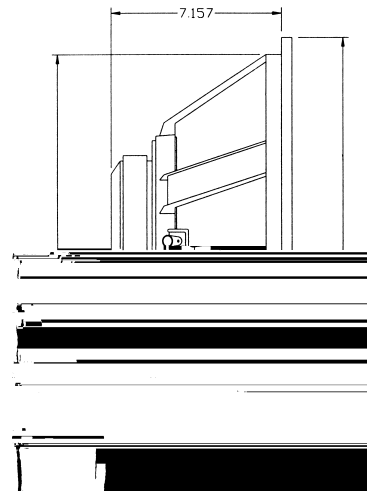

Specifications subject to change without notice.

LIMITED WARRANTY

Radian Audio Engineering, Inc. products, when sold domestically, are guaranteed for a period of five (5) years from the date of original purchase against malfunctions due to defects in workmanship. If such a malfunction occurs, the product will be repaired or replaced at our option, without charge, if delivered prepaid to the factory. Product will be returned prepaid via ground transport. This warranty does not extend to damage resulting from improper installation, misuse, neglect or abuse. The warranty does not apply to external finish or appearance. The warranty does not apply to burnt voice coils. In no event shall Radian Audio Engineering, Inc. be liable for incidental or consequential damages including, without limitation, injury to persons or property or loss of use.

600 N. Batavia Street
 Orange, CA 92868
 Phone: (714) 288-8900
 Fax: (714) 288-1133
 E-mail: radian@radianaudio.com
 Web: www.radianaudio.com